

Power Transmission Engineering
Fluid Power



Motion, Drive & Automation



3rd Edition 2015

MDA Events Worldwide

Join the No. 1 Trade Fair Network for Motion, Drive & Automation

Turkey	Istanbul	19 - 22 Mar 2015
Germany	Hannover	13 - 17 Apr 2015
Brazil	São Paulo	30 Jun - 3 Jul 2015
China	Shanghai	27 - 30 Oct 2015
India	New Delhi	9 - 11 Dec 2015
USA	Chicago	12 - 17 Sep 2016
Italy	Milan	2016

www.hannovermesse.de/worldwide



Deutsche Messe



Power Transmission Engineering
Fluid Power



Motion, Drive & Automation



Content

Content

- 03** Editorial
Power Transmission Engineering and Fluid Power –
keep the world moving
- 04** Power Transmission Engineering and Fluid Power –
successful in global competition
- 06** Cutting-edge technology “Made in Germany”
- 08** “Motion, Drive & Automation” (MDA) and “MobiTec” –
two key exhibitions within the framework of the Hanover Fair
- 10** VDMA joint stands on trade fairs – in Germany and worldwide
- 11** Talent machine launched – VDMA opens youth portal and is
breaking new ground in promoting young talent
- 12** VDMA network abroad
- 14** Power Transmission Engineering and Fluid Power
Associations – the global service providers
- 15** Contact VDMA Power Transmission Engineering and Fluid Power
- 16** List of German suppliers
- 46** Company portraits
- 100** Imprint

Power Transmission Engineering and Fluid Power – keep the world moving



Wilhelm Rehm,
Chairman
Power Transmission
Engineering Association



Christian H. Kienzle,
Chairman
Fluid Power
Association



Hartmut Rauen,
Managing Director
Power Transmission Engineering
and Fluid Power Associations

Dear readers!

Power transmission engineering and fluid power keep the world moving.

German companies in these two industries deliver performance modules and system solutions to the world's best machine builders in the form of cutting-edge technology with premium quality.

This present guide to "Motion, Drive & Automation" provides an overview of the players involved in the VDMA in the form of a manufacturer directory and individual portraits of companies. At the same time, this publication offers information on a number of topics and the dates of various events and describes the economic and technological performance of the German power transmission engineering and fluid power industries.

We hope that you find the guide interesting and enlightening!

Power Transmission Engineering and Fluid Power – successful in global competition

Leading position of power transmission engineering and fluid power

German power transmission engineering and fluid power inspire customers around the world. This is clearly underlined by the leading position of these industries in terms of their world market share and their high volume of exports and sales.

Both industries have strengthened and consolidated their position in the world market over the years, despite increasing competition from abroad. Growth in recent years has been around 5 percent per year. In 2014, the power transmission engineering and fluid power industries were once again able to demonstrate their technology leadership.

With a total sales volume of more than 23 billion euros, these two innovative industries are the largest segment within the German mechanical engineering and plant construction sector and employ almost 130,000 people.

Development in the recent past was driven by customer industries dependent on automation, medical technology, mobile applications, the machine tool industry and the world wind power industry, which is now experiencing a recovery.

The situation is good, and the mood is generally positive. However, the world geopolitical situation and the resulting uncertainty mean that the industries can expect only modest investment among their customers. Nonetheless, with regard to 2015, industry representatives are predicting growth at the low end of the single-digit range and thus continued positive development.

A reliable and innovative partner for customers

Power transmission engineering and fluid power are supplier industries which attach great importance to research and development. They are accordingly the technological ground-breakers for

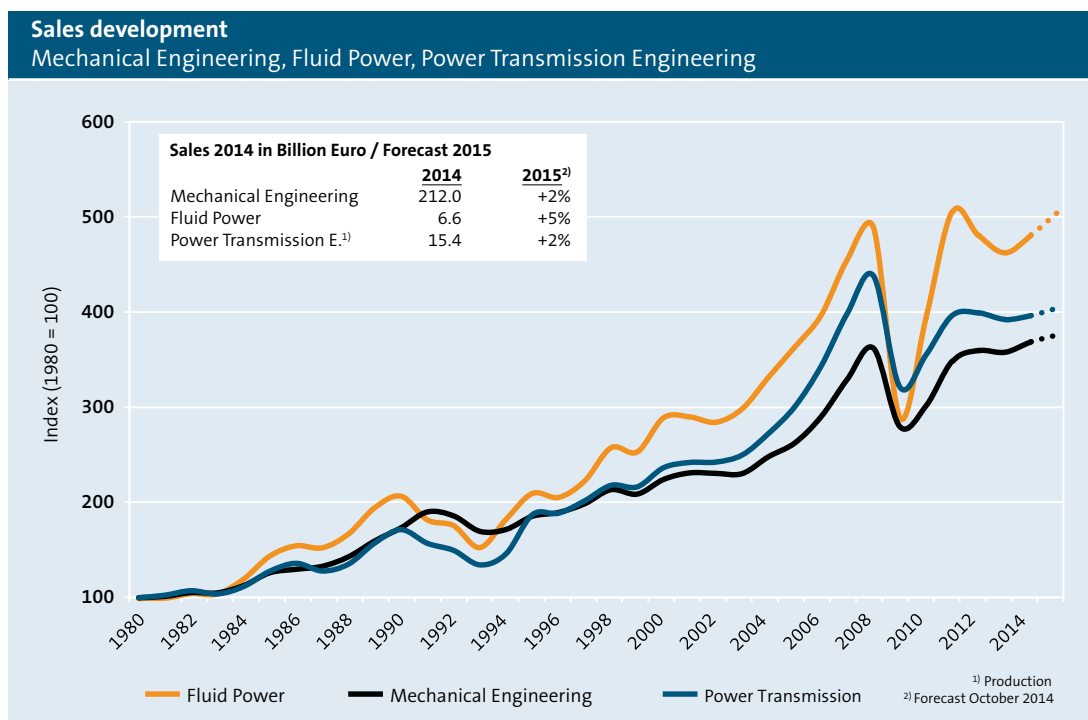

*Source: VDMA



all kinds of applications and requirements from markets and customers. Power transmission engineering and fluid power supply solutions for automation technology, construction machinery, printing machines, energy and environmental

technology (wind turbines and solar systems), conveyor technology, woodworking machinery, plastic and rubber processing machinery, agricultural machinery, aviation and space travel, medical technology, food and packaging machines, shipbuilding and machine tools.

German power transmission engineering and fluid power worldwide

The power transmission engineering and fluid power industries have been increasing their exports for years. Fluid power exports over 50 percent of its production, while the figure for power transmission engineering is as much as 80 percent, thus providing clear evidence of the high level of trust which customers worldwide place in cutting-edge German technology. It is no wonder that Germany has been the world’s export champion in both industries for many years.

Many German power transmission engineering and fluid power companies today produce directly in the areas to which they sell, with a special emphasis on China, India, Eastern Europe and the United States. Due to their strong export position, the power transmission engineering and fluid power technology industries are also able to support their clients in these markets with innovative solutions, the locally-required technology and customer-friendly service. The key export regions for power transmission engineering and fluid power include Europe, Asia and America. Customers worldwide rely on technology “Made in Germany”.

Power Transmission exports from the most important supplier countries
Shares in % of total exports*, 2013

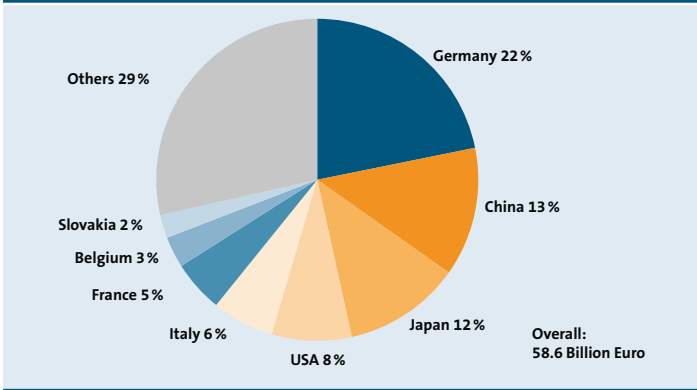

*Source: National statistical offices and VDMA Foreign trade data of 52 reporting countries

Fluid Power exports from the most important supplier countries
Shares in % of total exports*, 2013

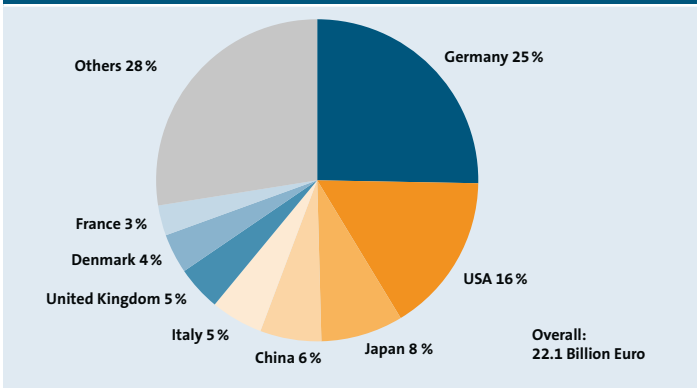

*Source: National statistical offices and VDMA Foreign trade data of 52 reporting countries

Cutting-edge technology “Made in Germany”

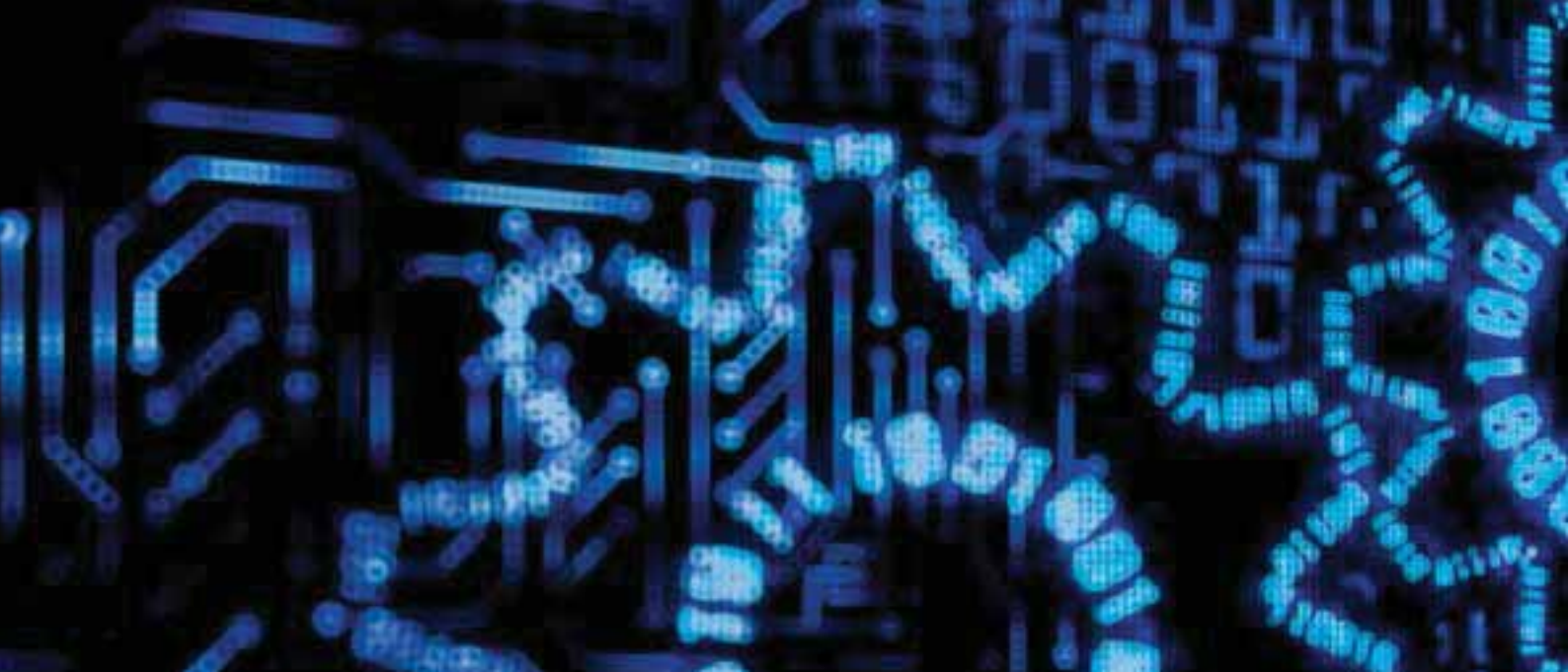

In today's increasingly harsh global competition, Germany's power transmission engineering and fluid power companies are scoring heavily with the latest technologies for all kinds of application areas throughout the value chain. As the most important suppliers to the whole area of machine building and plant construction, these two industries help meet political climate and energy targets and are dedicated to finding solutions to the new challenges of changing global markets. The philosophy "Think globally, act locally" is more important today for industrial suppliers than ever before. Despite the clearly intensifying competition, the classic industrial products of the power transmission engineering and fluid power industries help secure Germany's future as a location for industrial production.

In order to maintain this position, many companies have already launched their mission for the future – to translate the opportunities and possibilities of the fourth industrial revolution "Industry 4.0" into practical benefits. This will require the networking of digitised products with their means of production and the real-time exchange of data along the entire value chain and the creation of new digital business models. Companies which are already today engaging with the topic of Industry 4.0 expect to see tangible benefits from the fusion of information technology and mechanical engineering. Workpieces and production machines which communicate with one another will open the way to new processes and organisational structures. Industry 4.0 will allow completely new approaches to fulfilling the increasingly stringent requirements with regard to energy and resource efficiency as well as flexibility and individualisation in production operations. New business models, enhanced after-sales service, the use of "total cost of ownership" methods and condition monitoring systems, all of which have already been adopted intensively by the industries, will be expanded further.



The fundamental expectation or requirement of the operators of machines and plants is for high productivity and operational safety and reliability. These requirements are being met by speeding up the development processes of components and systems. Among the key factors here, to

Industry 4.0 offers German companies the opportunity to expand their worldwide leading position in the field of production technology.

name but two, are greater use of simulation tools to optimise design and an increasing level of mechatronisation. Customers must be able to rely on being offered the most efficient drives possible. This also means close cooperation between suppliers and customers in the dimensioning of components and systems to match customers' specific processes.

Other important criteria are boosting the digitisation of components and systems, modularization and last but not least the resource-saving use of materials and energy. The criterion of energy efficiency in industrial processes in particular is the main challenge of the present time for manufacturers and also operators, and will undoubtedly remain so in the future.

The future of cutting-edge technology “Made in Germany” of course presupposes that the technological leaders in the main client industries remain located in Germany, together with the suppliers of important basic technologies such as, for example, open- and closed-loop control technology, sensor technology and production technology.

Physical proximity and synergistic relationships between suppliers and client industries lead to a climate in which new concepts and new solutions are generated.

“Motion, Drive & Automation” (MDA) and “MobiliTec” – two key exhibitions within the framework of the Hanover Fair

With 10 international key exhibitions, the Hanover Fair 2015 will act as a focus for the key technologies of the industry and thus produce a horizontality which is unique throughout the world. The concept of the fair as a platform for the interaction of all the participating sectors and technologies is unrivalled: nowhere else can interested parties gather information on all the areas involved in value creation as comprehensively and in such an integrated form as here. The most important industries show their strengths and use interdisciplinary knowledge transfer to promote bridge-building to other related technologies.

As part of this leading world exhibition, Motion, Drive & Automation (MDA) is held every two years. This event, by far the world's most important exhibition of the key components of industrial automation, allows interested parties to gather information from some 1,100 exhibitors from 36 nations (figures from 2013) regarding innovative concepts and solutions from international manufacturers.

As manufacturers of core components for every industrial application, power transmission engineering and fluid power companies are the suppliers of the most important basic technologies throughout industry. The MDA every two years is therefore a major meeting point for designers, engineers, researchers and managers from the capital goods industry all over the world. At the upcoming event on 13 – 17 April 2015, “Integrated Industry – join the network!” will be the key theme of the entire Hanover Fair. This key theme underlines the fact that the main challenges of Industry 4.0, such as generally applicable standards for machine-to-machine communication, the question of data security or the search for the business model of the future, can be met only through networks.

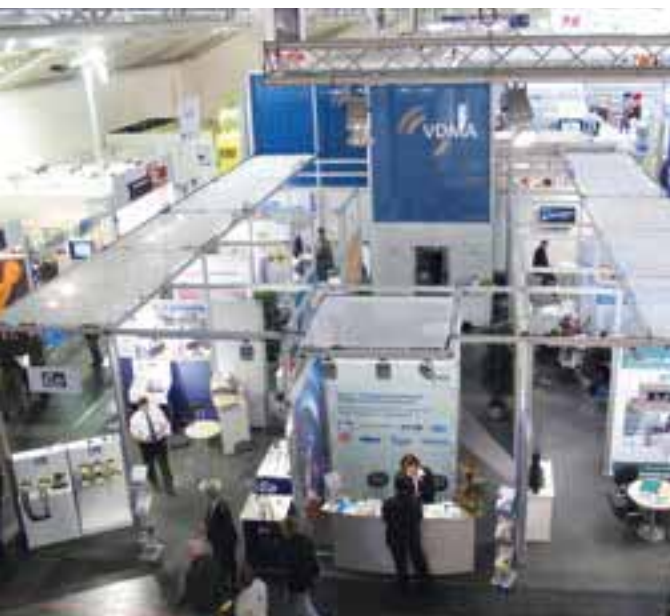



MDA Forum

In 2015, once again an MDA Forum will be organised in Hall 24 with the thematic areas of

- Industry 4.0
- Sustainability/energy efficiency, lightweight construction
- Power Transmission Engineering for wind turbines
- Sealing technology
- Condition monitoring systems

In the past years it was very well received by visitors.

MobiliTec: Leading international exhibition of hybrid and electrical drive technologies, mobile energy storage devices and alternative mobility technologies

MobiliTec

Right from the start, the VDMA and the Research Association for Drive Technology (FVA) were ideal candidates to support MobiliTec, which offers players throughout the value chain an attractive forum to display products concerned with all aspects of the mobility technologies of tomorrow.

Embedded in the Hanover Fair, which is held each year in April, MobiliTec offers an attractive platform to present know-how from the fields of electric and hybrid drive technologies, energy storage and charging technologies and the production technologies for these. At the same time, MobiliTec benefits from links to further main themes of the Hanover Fair, including Motion, Drive & Automation (MDA), Energy and Industrial Automation (IA).

The VDMA electromobility forum E-MOTIVE also plays a central role in MobiliTec with a shared stand. This presents selected projects from joint industrial research and the numerous activities within the innovation network, drawing on the best examples from research, industry and science relating to all facets of electromobility.



VDMA joint stands on trade fairs – in Germany and worldwide

2015 – Germany*

- Motion, Drive & Automation (MDA)
at HANOVER FAIR
13 – 17 April 2015
VDMA joint stand
in hall 24
- AGRITECHNICA incl. Systems & Components
Hanover
8 – 14 November 2015
VDMA joint stand

2015 – Worldwide

- WIN Automation
Istanbul, Turkey
19 – 22 March 2015
German Pavilion
- PTC ASIA
Shanghai, PR China
26 – 29 October 2015
German Pavilion
- WIN INDIA
New Delhi, India
9 – 11 December 2015
German Pavilion

*only for VDMA member companies

Plan 2016 – Germany*

- bauma
Munich
11 – 17 April 2016
VDMA joint stand
- Industrial Automation (IA)
at HANOVER FAIR
25 – 29 April 2016
VDMA joint stand

Plan 2016 – Worldwide

- WIN Automation
Istanbul, Turkey
March 2016
German Pavilion
- MDA NORTH AMERICA
at IMTS (International Manufacturing
Technology Show)
Chicago, USA
12 – 17 September 2016
German Pavilion
- PTC ASIA
Shanghai, PR China
October 2016
German Pavilion
- WIN INDIA
New Delhi, India
December 2016
German Pavilion



Contact

Ms. Ann-Catrin Rehermann
Phone +49 69 6603-1317
E-Mail ann-catrin.rehermann@vdma.org

Ms. Solveig Thiede
Phone +49 69 6603-1744
E-Mail solveig.thiede@vdma.org

Talent machine launched – VDMA opens youth portal and is breaking new ground in promoting young talent



The VDMA officially launched its new youth portal [talentmaschine.de](https://www.talentmaschine.de) in mid-2014. This is aimed at school and university students who are interested in technology and young people who are looking for a training position, an internship or a traineeship. Currently, 85 companies from the mechanical engineering and plant construction industries have posted around 1,000 offers.

“With the ‘talent machine’, we aim to generate interest among young men and women in mechanical engineering and plant construction, inform them about professional and career opportunities and make them concrete offers”, noted VDMA President Reinhold Festge at the launch of the youth portal in Frankfurt.

For many companies, it is becoming increasingly difficult to find qualified young people to undertake training, dual study courses or internships. This applies especially to rural areas. With [talentmaschine.de](https://www.talentmaschine.de), a modern system is available to VDMA members (around 3,200 companies) which is intended to help with recruitment.

“[talentmaschine.de](https://www.talentmaschine.de) saves our member companies time and money“, said Festge. All job offers can be generated and administered centrally in the new portal and published simultaneously on free and paid-for job portals at the click of a

mouse. By bundling the offers together, the VDMA was able to secure more favourable terms for its members in the case of paid-for portals.

The VDMA is also breaking new ground in the way it addresses young people. The slogan of the new portal: “[talentmaschine.de](https://www.talentmaschine.de) – you make the technology that moves the world.” This slogan is intended to attract in particular young people who are suited to technical professions but have not as yet thought about a career in mechanical engineering and plant construction.

“We do not need to advertise to techies,” explained Jörg Friedrich, Head of the Education at the VDMA. “We wish in the future to emphasise even more clearly that mechanical engineering offers not only good career prospects and earnings potential but more besides.” Technical solutions make sense and generate large benefits to society.

Of course, young people from outside Germany can also access [talentmaschine.de](https://www.talentmaschine.de) and consider starting their professional future here.

VDMA network abroad

The representations of the VDMA in Kolkatta, Moscow, Beijing, São Paulo and Tokio serve as international bridgeheads between governmental organisations, associations and companies. Local German speaking employees facilitate the market entry for VDMA member companies. Besides it promotes the activities of VDMA member companies all over the world.



VDMA Representative Office Brazil

Contact

Thomas Junqueira Ayres Ulbrich, Office Manager

(Correspondence: German, Portuguese)

Phone +55 11 430580-42/-43

E-Mail thomasjaulbrich@vdma.org

Internet brazil.vdma.org

VDMA Representative Office India

Contact

Rajesh Nath, Managing Director

(Correspondence: German, English)

Phone +91 33 23219522

E-Mail vdmaindia@eth.net

Internet india.vdma.org/en

VDMA Representative Office P.R. China

Contact

Stephanie Heydolph, Office Manager

(Correspondence: German, English)

Phone +86 10 87730212-808

E-Mail heydolph@chinavdma.org

Internet china.vdma.org/en

VDMA Representative Office Japan

Contact

Holger Wittich, Office Manager

(Correspondence: German)

Phone +81 3 3363-6632

E-Mail wittich@vdma-japan.com

Internet vdma-japan.com

VDMA Representative Office Russia

Contact

Sven Flasshoff, Office Manager

(Correspondence: German, Russian)

Phone +7 985 6437765

E-Mail sven.flasshoff@vdma.ru

Internet russia.vdma.org/home



Activities in the past three years

- Organisation of Management-Meetings in China and India (2x/year)
- Representation on sector specific trade fairs like PTC ASIA, MDA SOUTH AMERICA and WIN INDIA
- Organisation of the MDA Forum as part of WIN INDIA
- India Fluid Power Industry Report (4x/year)



Services – freely requestable for members

Establishing of contacts

- Ministries/Associations
- Trade and business press
- Trade Fair organisers

Market penetration

- Site research
- Trends/Potentials
- Newsletter/Industrial reports (China, India)

Network

- Entrepreneur meetings
- Embassy/Consulates
- Local administration

Lobbying/Monitoring

- Representation of industry interests
- Observation of the local legal conditions
- Standardisation activities (China)

Special services

against compensation of expenses

- Establishment of offices/ foundation of companies
- Personnel recruitment
- Market analyses
- Visas-invitations
- Provision of interpreting services
- Registration of trademarks
- Provision of legal and tax counselling
- etc.

Office-in-Office in China

- Provision of a fixed-term workplace for a VDMA member
- Particularly appropriate before establishing a representation or company in China (reduction of costs and risks during the initial phase of the market entry)



Power Transmission Engineering and Fluid Power Associations – the global service providers

The VDMA Power Transmission Engineering and Fluid Power Associations represent the interests of just under 400 member companies, the largest body of subcontractors to the German mechanical engineering industry, to the worlds of politics, national and international authorities, customers, supplier and competitor organisations and the general public. Above and beyond this, the associations look after the industry-specific interests of the power transmission engineering and fluid power industries within the VDMA, the German Engineering Federation.

The associations regard themselves as industry-specific service providers and advisers. They are able here to turn to the VDMA as an experienced and competent partner which represents the entire mechanical engineering industry. Thanks to their positioning within the VDMA, the associations are also able to work together with the

other 36 VDMA associations and the local state associations to provide contacts and information on the industry's most important client groups such as agricultural machinery, construction machinery, robotics and automation, machine tools, printing machinery and paper technology. The liaison offices are the first point of contact for clients outside of Germany.

The main activities of the associations include the representation of technical interests, standardisation, market information, statistics and industry-specific PR work, trade fairs and exhibitions.

Joint research is amply provided for by the Research Association for Drive Technology FVA (fva-net.de) and through the Fluid Power Research Fund (fluid.vdma.org). In the area of international cooperation, the two associations provide the General Secretariats of the European industry committees EUROTRANS (euro-trans.org) and CETOP (cetop.org). Moreover the fluid power association forms the secretariat for International Fluid Power Statistics.

The VDMA E-Market is a search platform for the products of the German capital goods industry. Its target groups are designers, developers, production engineers and technical buyers (vdma-e-market.com).



ant.vdma.org/en
fluid.vdma.org/en
vdma-e-market.de/en



Contact VDMA Power Transmission Engineering and Fluid Power

Chairman

Power Transmission Engineering Association

Wilhelm Rehm
Member of the Board
ZF Friedrichshafen AG
Friedrichshafen
Germany

Chairman

Fluid Power Association

Christian H. Kienzle
CEO
ARGO-HYTOS GMBH
Kraichtal
Germany

Managing Director

Power Transmission Engineering and Fluid Power Associations

Hartmut Rauen
Phone +49 69 6603-1331
E-Mail hartmut.rauen@vdma.org

Assistance:

Pamela Schäfer
Phone +49 69 6603-1332
E-Mail pamela.schaefer@vdma.org

European Sector Committees

CETOP (Fluid Power)

General Secretariat:
Sylvia Grohmann-Mundschenk
Phone +49 69 6603-1319
E-Mail info@cetop.org
Internet cetop.org

EUROTRANS

(Gears and Transmission Elements)

General Secretariat:
Dirk Decker
Phone +49 69 6603-1685
E-Mail dirk.decker@vdma.org
Internet euro-trans.org

FEBMA (Bearings)

General Secretariat:
Dr. Andreas Rowold
Phone +49 69 6603-1624
E-Mail andreas.rowold@vdma.org

Your Specialist for Industrial Damping Technology



Automation Control



Motion Control



Vibration Control



Safety Products

We absorb the shock, so you don't have to

ACE is the worldwide accepted specialist in the field of industrial damping technology – with distributors in 45 countries on all continents. Since 1978 ACE has been represented very successfully on the German market.

Here alone 25 application engineers are working day in day out on the improvement of ACE's product range. Customers of ACE benefit from our well-thought-out solutions, useful innovations and exemplary service in 'damping technology'. Through close co-operation with leading machine manufacturers the ACE subsidiary in Germany has established itself as a precursor of technical progress.

Top products enhanced by service

ACE develops, produces and distributes a wide range of damping products. These include industrial and safety shock absorbers, profile dampers, rotary dampers, industrial gas springs, hydraulic dampers and feed controls. Our portfolio of vibration isolation is completed by the ACEolator product range and the new "VibroChecker" App for the iPhone™.

These products succeed especially in future-oriented businesses as there is virtually no better damping solution to decelerate moving masses quickly, softly and precisely.

The advantages for our customers are obvious:

- Competent personal counselling on site and by phone
- Individual dimensioning for the client
- Delivery of small quantities, even one piece without extra charge
- Elaborate accessory range
- Realistic prices
- Shortest delivery times



ACE, BIBUS Kft and Semilab Semiconductor Physics Laboratory Co. Ltd.



ACE/Bosch Rexroth AG

ACE is a partner of the Research Fund





Fluid Power Technology has been our passion for over 65 years



As a medium-sized family business with more than 1300 employees worldwide ARGO-HYTOS has more than 65 years of experience in Fluid & Motion Control and Filtration technology in mobile and industrial hydraulics.

Filtration

ARGO-HYTOS manufactures sophisticated filter solutions, mainly applied in hydraulic and lubrication systems as well as in transmissions, for the mobile and industrial hydraulics industry.

Fluid Management

Besides reducing maintenance and servicing costs, efficient fluid management is also a key factor in improving the reliability, productivity and cost-effectiveness of the operation. ARGO-HYTOS supplies application-oriented products for manual and automatic cleaning of hydraulic fluids.

Sensors & Measurement

Systems that provide reliable assessment of the condition of hydraulic fluids are the key feature of continuous fluid monitoring. Sensors and measurement technology from ARGO-HYTOS precisely target this range of tasks. Our fluid monitoring products comprise equipment and system solutions to enable online monitoring during continuous operation as well as analysis of bottled samples under laboratory conditions.

Fluid & Motion Control

We produce a wide range of valves, power units and integrated manifolds featuring all commonly used design features and functions, together with proportional valves and the associated control electronics.

Our strength is in developing customised solutions based on tried-and-tested fundamental technologies, specifically adapted to each individual case.



Fluid Control Valves, Fluid Power Components and All-in-One Systems for Fluid Automation

With 4,700 employees worldwide, ASCO Numatics – a division of the EMERSON Group of companies – is a global leader in the field of fluid control and fluid power. At our location in Germany, 230 employees focus on the development and manufacture of proportional valves, valves for analytical and medical technology, valve islands as well as dedicated custom solutions for fluid automation.

ASCO Numatics' portfolio includes solenoid valves for the control of gases and liquids ranging from inert to aggressive. Pressure ranges extend from vacuum up to 350 bar. Nominal diameters range from 0.03 mm up to 100 mm.

Another key area is our range of fluid power components with its large choice of cylinders, valve islands, air-operated valves and air preparation equipment.

Pioneering innovations from Germany have attracted attention worldwide. Taking the first

step towards Industry 4.0, our high-resolution proportional valve "SENTRONIC HD" is among our latest developments. Our tried-and-tested "SENTRONIC" series was further developed and successfully introduced on the market under the name "SENTRONIC PLUS".

New valves for analytical and medical technology are also continually being developed and manufactured at the location in Germany. This includes the proportional flow control valve type "PRECIFLOW-IPC" which is especially conceived for breathing apparatus. Under a new series "068", ASCO Numatics also successfully launched a 16-mm wide fluid-isolation flapper valve for analytical technology at the beginning of 2014.

When designing products, we place great emphasis on plug & play. As a systems partner, we can provide our customers with bespoke all-in solutions (valve technology, electronics, sensors and software) uniquely suited to their application needs – all from a single source. Here too, as with all our developments, our focus is on reliability and ease-of-use.

Innovative products – custom made solutions



The name Barksdale represents high quality sensors and switches in the area of measurement and control functions.

For more than 50 years Barksdale has developed and manufactured custom-made and future-oriented solutions to control pressure,

temperature, level and flow.

Proximity to the markets and the dialogue with the customers are the basis of Barksdale's success. By means of the world-wide sales network as well as new developments and modifications of standard products, our customers' demands can be realised fast and individually. Of course, our products meet the highest quality standards in terms of accuracy and performance with On Time Delivery being a top priority.

Whether in mobile or stationary hydraulics, ship-building or mechanical engineering, Barksdale meets high safety standard in many markets. Barksdale is a division of Crane.Co. Stamford CT.

Barksdale
CONTROL PRODUCTS

Barksdale GmbH • Dorn Assenheimer Str. 27 • 61203 Reichelsheim • Germany
Phone +49 6035 949-0 • E-Mail info@barksdale.de
Internet www.barksdale.de



In 1927, the Esslingen entrepreneur Wilhelm Bauer began to free tool and production machines from the need for cumbersome transmission shafts. He translated the ingenious idea of a geared motor into reality, equipping a high-speed electric motor with a gear wheel mechanism using the appropriate gear ratio.

Innovation since 1927

In the several decades since then, a knowledge base has been formed and is constantly being added to and passed on. It is not without reason that the Bauer brand has grown in world renown; and Bauer continues to build extremely efficient geared motors today.

We offer application-specific solutions for many sectors on the basis of our modular geared motor program. Our aim is to tailor the product to the customers' needs, while ensuring that our geared motor solution proves profitable well beyond its entire life cycle.



Bauer
Gear Motor
An Altra Industrial Motion Company

Bauer Gear Motor GmbH • Eberhard-Bauer-Str. 36-60
73734 Esslingen am Neckar • Germany
Phone +49 711 3518-0 • E-Mail info@bauergears.com
Internet www.bauergears.com



Baumüller – be in motion

Baumüller, a pioneer in drive technologies, plans and delivers innovative drive and automation designs – from software to machine control systems, all the way to the motor and power transformers.

The Baumüller Group of companies, with its main office in Nuremberg, is a specialist in intelligent electrical automation solutions and drive systems. At over 40 sites worldwide, our employees plan, develop, manufacture and assemble innovative system solutions for the mechanical engineering and factory automation, renewable energy and electrical mobility sectors.

With our comprehensive product portfolio, ranging from software and control systems to transformers, electro motors, switch cabinets and switching systems, Baumüller provides complete systems for standard and custom machines from a single source.



Baumüller Group • Ostendstr. 80 – 90 • 90482 Nürnberg • Germany
 Phone +49 911 5432-0 • E-Mail mail@baumueller.de
 Internet www.baumueller.de

Your Partner for Hydraulic System Solutions



Bucher Hydraulics is an internationally leading provider of innovative drive and control technologies. Contributing high levels of technical expertise, we support our clients' product development activities from the initial project phase to the finished machine. From planning to production, we can provide valuable help in creating very

advanced machinery that features stringent technical demands and exacting quality standards.

We provide components, sub-systems and complete systems with emphases on pumps, motors, valves, cylinders, power units, manifold control blocks, and electronic control systems. Bucher Hydraulics develops tailor-made and cost-effective applications that provide optimum performance in the areas of:

- Construction Machines
- Materials Handling
- Municipal Equipment
- Renewable Energy
- Agricultural Machines
- Mechanical Engineering
- Elevator Technology



Bucher Hydraulics GmbH • Industriestr. 1 • 79771 Klettgau • Germany
 Phone +49 7742 852-0 • E-Mail info@bucherhydraulics.com
 Internet www.bucherhydraulics.com



Variable-speed drives with asymmetrical variable speed pulleys, „Becker” system



BERGES variable-speed drives with symmetrical variable speed pulleys



BERGES... everything under control

Shortly after the brothers Carl and Wilhelm Berges founded the company in 1926, BERGES concentrated on the infinitely variable, mechanical drive technology range. In 1971, a subsidiary was formed in Naturns, South Tyrol, followed by expansions to Switzerland and Great Britain. With the acquisition of the “System Becker” asymmetrical pulley technology in 2003, BERGES is now the specialist in mechanically variable pulley technology with the widest range of products.

Mechanical speed regulation covering a power range of 0.25 to 200 kW.

Drive technology in machinery and plant engineering needs an economical speed regulation. Our mechanical infinitely variable V-belt drives convert power into precisely the speed that is currently needed, while maintaining optimum motor efficiency.

We can deliver an appropriate system for every application field: standard and wide V-belt technology, single and double pulley drives, spring and cam pulleys, ready-to-fit assembly units, all suitable for upgrading with three-phase motors and reduction gears.

The requirements for precise speed control vary with technical conditions. According to that, BERGES delivers spindle and angle adjustment devices with hand wheels or scale wheels, hydraulic and electric remote controls, including speed indicators and tachometers.

As a leading specialist, BERGES not only provides proven technology of the highest quality, but also substantial application specific consulting services.



BERGES Antriebstechnik GmbH & Co. KG
Industriestr. 13 • 51709 Marienheide
Germany • Phone +49 2264 17-0
E-Mail info@berges.de
Internet www.berges.de

BERGES Italiana s.r.l.
Via Peter Mitterhofer 21
39025 Naturns/Bz. • Italy
Phone +39 473 673600
E-Mail info@bergesitaliana.it
Internet www.bergesitaliana.it

Production control, traceability, quality assurance and the vision of Connected Industry demands an ever stronger flow of information from automation to IT and back again. Within the framework of Open Core Engineering, Bosch Rexroth makes it possible to collect and evaluate production data from a machine quickly using the MS Office software "Excel" or to use results from simulation software directly for production. Machine manufacturers therefore are bridging the gaps between the PLC world and the IT world and can take direct hold of the key functions of controls and drives with high level languages.



Bosch Rexroth links automation to IT



main drive
for servo presses



IndraMotion
MLC for hydraulics

With a finely scalable range of motion controls for the control and actuator level, Rexroth covers the requirements of Connected Industry with regard to hydraulic actuators as well. Using decentralised intelligence and open standards for communication, the Motion Controls fulfil the requirements for horizontal and vertical integration. They act autonomously and integrate themselves

independently into a changing context. Machine manufacturers can thus combine the physical advantages of the hydraulic system, such as a high power density, with the requirements of Connected Industry.

The topic of energy efficiency also plays an important role in the vision of Connected Industry. Here, Rexroth offers numerous pre-defined function packages to optimise, for example, the energy consumption in electrohydraulic applications as well as to monitor and control the performance of electrical consumers. Further

efficiency potential lies in the intelligent interaction of all applications at the factory level. As the only company to offer interface technology that is integrated into Open Core Engineering, Rexroth is already developing these potentials now. This way, end users can measure the energy consumption of all machines in their factory up to the actuator level and evaluate the data online. Furthermore, IT can directly access all machine controls via the Open Core Interface and optimise the energy efficiency of the whole value stream.

Connected Industry places new demands on machines and systems. As a specialist in drive and control technology, Bosch Rexroth is driving networking forward and helping machine manufacturers to develop their machines further for the future.

Your specialist and supplier



The ever increasing demand for factory automation and effective system communication poses as a challenge for the design of modern power packs and lubrication systems. The Bühler fluid power products are dedicated to meeting the requirements of these special market segments.

Bühler products meet requirements of small spaces, involve low financial investment, offer reliable operation, efficient Condition Monitoring and low cost of ownership.

The new product sensors include types for IO Link communication and are suitable for deployment in hazardous areas. The comprehensive product range of Air/Oil cooling systems has been enhanced by a number of ATEX classified versions.

Today, Bühler is an internationally known component supplier to the power pack and lubrication system markets. Subsidiaries and distributors of Bühler are located in over 15 countries around the world.



Bühler Technologies GmbH • Harkortstr. 29 • 40880 Ratingen • Germany
 Phone +49 2102 4989-0 • E-Mail info@buehler-technologies.com
 Internet www.buehler-technologies.com

Elastomer Seals from the Specialist



C. Otto Gehrckens GmbH & Co. KG – COG for short – is an independent manufacturer regarded throughout the industry as one of the leading providers of elastomer seals. COG dispatches consignments featuring a highly diversified range of materials, including FFKM, from the world's largest O-ring warehouse (more than 45,000 items in stock) and has been offering German premium quality, experience and innovative capability for more than 145 years.

COG at a glance:

- Founded in 1867 in Pinneberg, near Hamburg
- Independent family-owned company with more than 200 employees
- World's largest O-Ring warehouse (over 45,000 items in stock)
- Tools for over 22,000 different O-Ring sizes available
- In-house mixing and mixture development
- Various materials, e. g. FKM, FFKM/FPM, NBR, VMQ, HNBR, PTFE and FEPM
- Releases and approvals granted for many materials and to hand
- Own tool manufacture



C. Otto Gehrckens GmbH & Co. KG • Gehrstücken 9 • 25421 Pinneberg • Germany
 Phone +49 4101 5002-0 • E-Mail info@cog.de
 Internet www.cog.de/en



Engineering Tomorrow connects proven performance with exceptional efficiency

Danfoss Power Solutions is a world leader in hydraulic solutions and electronic controls that power and propel the equipment that builds our world. We provide know-how in motion to a wide array of industries – including construction, agriculture, material handling and more.

Learn more about Danfoss Power Solutions at powersolutions.danfoss.com

Danfoss engineers solutions that enable the world of tomorrow to do more with less. We help meet the growing need for infrastructure, food supply, energy efficiency and climate-friendly solutions. Across our total business, our products and services are used in areas such as refrigeration, air conditioning, heating, motor control and mobile machinery. We are also active in the field of renewable energy as well as district heating infrastructure for cities and urban communities. Danfoss' innovative engineering dates back to 1933 and today we are a world-leader in our industries, employing 22,500 people and serving customers in more than 100 countries. We are still privately held by the founding family. Read more about us at www.danfoss.com.



THE SOLUTION FOR EVERY DRIVE!

DESCH Antriebstechnik GmbH & Co. KG offers products, solutions and services along the entire drive line.

DESCH is a leading manufacturer and importer of drive elements and is a worldwide leader in the area of clutch technology, for construction

machines, plastic and farm machinery, presses and pump-sets. DESCH produces and sells planetary and special gears for applications like centrifuges, parabolic antennas and testing stations, and is the world's market leader in the area of complete press drives. Products in this category are also used for machine tools and other areas within the construction machinery industry. The DESCH Service Centre offers engineering services, technical support and assembly. All business areas of DESCH work hand in hand to produce the most innovative and customised solution from "one source" for your drive requirements.



DESCH Antriebstechnik GmbH & Co. KG • Kleinbahnstr. 21 • 59759 Arnsberg • Germany
Phone +49 2932 300-0 • E-Mail info@desch.de
Internet www.desch.de

Efficiency through precision



Highest reliability, proven technology and optimal profitability have been the main features of EICOGEAR wind turbine gearboxes for over 20 years. Almost 7,000 wind turbine gearboxes made by Eickhoff convert wind with a capacity of more than 14,000 MW into clean power.

Since the early 90s the Eickhoff Antriebstechnik GmbH from Bochum has been an established supplier of wind turbine gearboxes. The high level of vertical range of manufacture, technical expertise and extensive experience in the wind power industry guarantee the ongoing business success of Eickhoff and high quality of its products. The EICOGEAR wind turbine gearboxes are steadily developed in close collaboration with customers and technological innovations get promoted. The EICOGEAR product range includes wind turbine gearboxes with outputs from 2 to 3.8 MW and customer optimised service concepts. All gearboxes are tested on internal test benches and prototypes are subjected to extreme operating conditions. In 2009, the new production facility Eickhoff Wind Power near Dresden started its series production of wind turbine gearboxes.



Eickhoff Antriebstechnik GmbH • Am Eickhoffpark 1 • 44789 Bochum • Germany
Phone +49 234 975-0 • E-Mail getriebe@eickhoff-bochum.de
Internet www.eickhoff-bochum.de

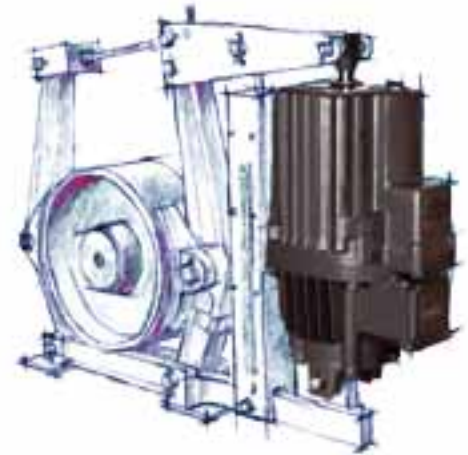

EMG Automation GmbH – Your partner for innovative solutions

The EMG Group operates independently around the world within the framework of our global strategy in the field of investment goods relating to control and automation technology. EMG products and system solutions are applied to continuous production processes in the metal, paper and plastic industries as well as in foil and tyre production.

EMG is a subsidiary of the listed company elxis AG with a headcount of more than 350 at its headquarters in Wenden, Germany. With own sales and service offices or representatives, the elxis group is present in more than 70 countries worldwide and serves more than 7,500 customers.

Business Unit Thrusters

In addition to a wide range of applications in the mechanical engineering industry, materials lifting and handling can be considered as the main uses of industrial brakes offered on the market. Drive and brake problems can be solved using a drum brake or a shoe brake which is still

quite common or by using industrial type disk brakes. As the requirements with respect to driving power, controllability and availability have clearly increased, advanced electrical engineering and electronics have become ever more important catering for these demands. Although most components of modern systems are electrical and electronic, the mechanical safety brake, with the electro hydraulic ELDRO® brake thrusters, still has the most important role to play: as the last link in the chain, it ensures safety for man and machine in the event of power failure.

ELDRO®- and ELHY®-thrusters of the EMG Business Unit Thrusters have coped since decades with their key position with regard to functional reliability, product life time and therefore high availability. A precise production with permanent controls within the entire production cycle, optimization by design to accommodate the increasing demands by usage under extreme climatic conditions, as well as technical innovations brought in by the suppliers industry, are the components that back up the worldwide good reputation of EMG's ELDRO®- and ELHY®-thrusters.



With more than 1.800 employees and a turnover of more than EUR 240 mio. the ETO GROUP is internationally leading in innovative electro-magnetic actuators and sensors for the automotive industry. The ETO-components are providing solutions for highly dynamic switching and control processes with highest reliability. Therefore, they are primarily used for control and regulation of engines, automatic gearboxes, brake systems for driving dynamics, as well as for efficiency control of ancillary units.



Megatrend efficiency increase in engines and gearboxes



In commercial vehicles, gearboxes, brake and air suspension systems are being regulated pneumatically by ETO products. In the field of engine technology for passenger cars, they are actuating systems for cylinder-on-demand, cam stroke setting and phase setting of camshafts and regulate pumps and engine suspension.

Locations in Germany, Poland, China, India and USA are providing ETO customers with a global development and production network, thus supporting the regional purchasing and product strategies with innovative ETO products as well as „local for local“.

ETO is setting a high value on sustainability. The actuators and sensors which are developed for engines are effecting energy saving, reduction of exhaust emissions and a resource optimized extension of product lifetime. ETO customers are thus profiting from a substantial contribution to increase efficiency of their own systems. Customers all over the world are inspired by optimized production technologies, highest requirements on quality and competitiveness as well as by our commitment to be the leading innovator.

Thus, we are developing e. g. actuators for cam stroke setting, phase setting and for cylinder-on-demand which are directly reducing fuel consumption. The controlled engine suspension for vibration damping is being realized in innovative motor concepts.

Forming the future:

ETO is breaking new technological ground with its unique MAGNETOSHAPE® material. These monocrystalline magnetic shape memory materials can replace conventional armature systems in actuators and mechatronic systems. And this in spite of very high dynamics along with substantially less energy input and a higher lifetime than the one of today's drive systems. These characteristics allow this innovative material to be used also in a much wider range of applications, beyond ETO's current product portfolio. Particularly in the field of medical technology as well as aerospace industry, actuators based on the MAGNETOSHAPE® technology are offering a new range of application.

Did we meet your interest?

Then please visit our websites: www.etogroup.com or www.etogroup.com/magnetoshape.

The seal specialist





Original
Simmerring
and New
Polyurethan-
Generation

Freudenberg Sealing Technologies relies on material expertise and innovations “Often invisible. Always essential.”

That is the way to describe the products of Freudenberg Sealing Technologies, the global market and technology leader in seal technology. The company has the right answer for its customers – whether they need products for the smallest micro-pumps, or nearly frictionless mechanical face seals for vehicles, or seal rings two meters across for wind turbines.

With more than 17,000 employees, and about 2 billion euros in revenue, Freudenberg Sealing Technologies is the largest of the 12 sub-groups within the Freudenberg Group. The company is a supplier, development and service partner for customers in an extremely wide variety of market segments in the automotive and general industry.

The company’s success story began in 1929 with the development of the Simmerring, which set the standard in sealing technology. Today, the company offers globally a broad product range from made-to-order individual solutions to complete sealing packages.

Some key attributes of Freudenberg have led to high customer satisfaction: a well-founded material expertise, high quality and a structured innovation process that systematically drives

developments forward. Freudenberg Sealing Technologies is able to look back on decades of experience in material development. Its portfolio includes about 2,000 individual material compounds, each produced for special applications. Its new generation of polyurethane is a good example: It was developed for a wide range of uses. It is also more resistant to water and withstands greater temperature fluctuations than conventional materials. It is above all used in seals for heavy-duty machinery such as excavators and tractors.

Innovations are a key component of the company philosophy. In recent years, the company has been honoured with a number of awards, including the German Innovation Award, the German Innovation Award for the Climate and the Environment, the Manufacturing Leadership 100 Sustainability Award, and most recently, the TOP Innovation Award from the FAZ Institute. Its outstanding innovations include the mechanical face seal Levitex, which brings the company very close to realising the vision of a friction-free seal. Part of an innovative sealing solution for vehicles, gas lubrication Levitex makes it possible to reduce wear and decrease CO₂ emissions by up to a gram per kilometer.

Freudenberg Sealing Technologies has also demonstrated its capacity to innovate in railway technology. HALL 2.0 puts trains on the right track. And with the help of sensor technology, cameras and GPS, this actively controlled axle guide bearing charts the right course. The effect: greater safety, less wheel and rail wear, less noise and reduced energy consumption.

The Freudenberg Group has been under family ownership for more than 160 years. Its entrepreneurial success has been based on commercial prudence, financial solidity and a long-term orientation.

Festo is a leading worldwide provider of automation technology for factory and process automation. As a family owned business, Festo has become the global market leader in its sector over the past 50 years, thanks to its innovation and problem solving competence in the field of pneumatics, as well as a unique range of industrial training and vocational education programmes. Today, the company offers pneumatic and electric drive technology for factory and process automation, as well as the latest qualification solutions for the industrial environment.

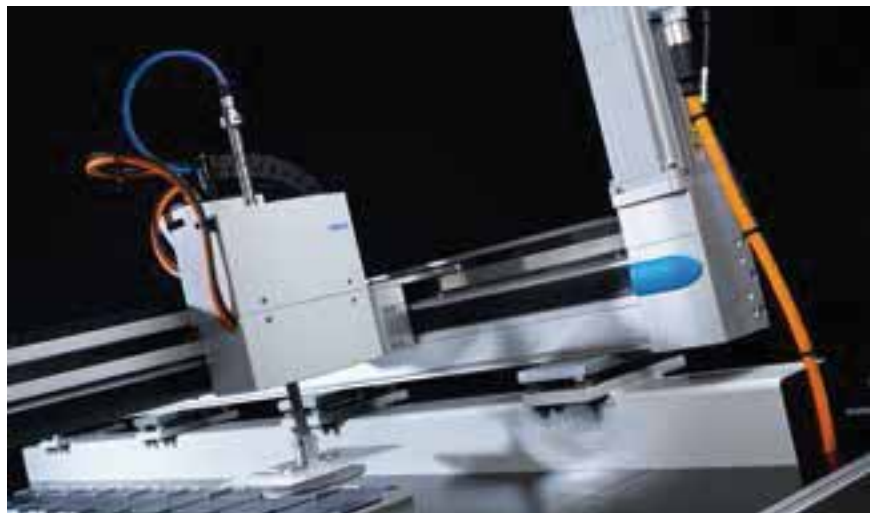

Moving with air – Festo's core competency



Innovation for the best possible productivity of our customers, global presence, long-term and close partnerships with our customers are the hallmarks of Festo. What is more, Festo uses the simplest drive medium in the world – air.

Innovation and variety for the world of automation

Our product portfolio for pneumatic and electric automation technology offers over 30,000 products for factory and process automation, from which customer-specific solutions can be created, thanks to a modular system with a wealth of optional variants. Festo's basic product range covers pneumatic and electric drives, valves, valve terminals, easy-to-install connection technology, handling and assembly technology, compressed air preparation, connection technology, vacuum technology, position and quality inspection, sensors and control tech-

nology and even extends to a comprehensive offer of industrial basic and advanced training programmes.

The company's spirit of innovation is reflected in the roughly 100 new products which are introduced to the market every year, as well as in the 2,900 patents registered around the world. Festo invests over 7 % of the turnover each year in basic research and the development of new products and processes. New approaches to product development using bionics and biomechanics represent a true first in the field of automation technology.

Wide range of training programmes for industrial applications

Festo has become a leading provider in the field of industrial training and education. The company has brought together a comprehensive series of learning systems for basic and advanced training in industrial areas.



INTEGRATED POWERTRAIN COMPONENTS, SYSTEMS AND SOLUTIONS



ENGINEERING > THAT MOVES THE WORLD

The GKN Land Systems Division of GKN plc is a global organisation with more than 5,400 employees worldwide in manufacturing, service and distribution facilities, and annual sales in excess of £ 899 million. Land Systems is, itself, one of four divisions within GKN plc; the others being GKN Aerospace, GKN Driveline and GKN Powder Metallurgy.

GKN plc is a global engineering business serving the automotive, aerospace and land systems markets. It has operations in more than 30 countries, around 50,000 employees in subsidiaries and joint ventures and had sales of £ 7.5 billion in the year 2013.

GKN Land Systems is a leading global supplier of technology differentiated powertrain products, solutions and services to the agricultural, construction, mining and utility and industrial sectors. Our product technology delivers the power to harvest crops, move earth, mine resources, handle materials and capture natural energy. Our growth is driven by the needs of an ever-increasing global population, the continuing rise in urbanisation and the drive for higher living standards, creating a need for more food, more raw materials and more energy.

What we do

We design, manufacture, market and service powertrain products and systems for leading global equipment manufacturers, helping our customers keep the world running efficiently, reliably and safely.

Our powertrain solutions deliver power from source to the point of application. We enable our customer's machinery to propel, position and perform in agricultural, construction, mining and industrial markets.

To achieve this, we engineer a wide range of products, systems and solutions:

- Driveshafts & Clutches
- Gearboxes
- Flexible Couplings & Brakes
- Integrated Drive Systems
- Wheels
- High Performance Structures
- Controls
- Electric and Hybrid Systems



GKN Walterscheid GmbH • Hauptstr. 150
53797 Lohmar • Germany
Phone +49 2246 12-0 • E-Mail info@gkn-walterscheid.de
Internet www.gknlandsystems.com

Hänchen Hydraulic solutions



There's no limit to the possibilities for the application of hydraulic drives. And almost no limit to the factors to be considered when looking for the best solution.

**100% made in Germany. 100% quality.
80% vertical integration.**

We have made this easy for our customers. Because Hänchen's complete service ranges from personal consulting to the interactive product configurator HÄKO. From the planning phase to the start-up. From individual cylinders and clamping devices to entire drive systems including documentation. From standard applications to custom-made special solutions.

Decades of experience will help us find the perfect solution for you.

Product variety: Hydraulic cylinder, Test cylinder, Clamping device Ratio-Clamp®, Pressure & fluid transformer, Drive system Ratio-Drive®, Machine elements



Herbert Hänchen GmbH & Co. KG
Brunnwiesenstr. 3 • 73760 Ostfildern • Germany
Phone +49 711 44139-0 • E-Mail info@haenchen.de
Internet www.haenchen-hydraulic.com

– Advertisement –



FVA-Workbench

The innovative simulation platform for drive technology

The FVA-Workbench centralizes more than 40 years of simulation competence of the Research Association for Drive Technology (FVA). Extensive simulation capabilities allow the modeling and detailed analysis of complex gear systems – from a single element to an overall system. Based on innovative features and the latest research results, the FVA-Workbench permits product development on a unique level.

- State-of-the-art simulations
- Expert support & individual consultancy
- High-class trainings & workshops
- Software development
- Flexible licensing



www.fva-service.com

HANSA-FLEX AG is a leading systems supplier for hydraulics. In addition to hose lines and connecting elements, HANSA-FLEX delivers a wide range of products from adapters to ZSS OW hoses.

The name HANSA-FLEX is globally synonymous with unrestricted customer proximity. A complete focus on customers and exemplary customer-oriented services make HANSA-FLEX the hydraulic partner of choice for companies from all sectors.



Service: Mission statement for all business activities



In the OEM department, these services even begin when planning new systems. HANSA-FLEX takes responsibility for engineering tasks, helps to build prototypes and supplies all hydraulic connecting elements from a single source. Highly qualified technical experts make sure that the hydraulic systems are correctly installed and commissioned

at customer sites. Services such as industrial assembly, fluid services and hose management enable the regular maintenance and preventative servicing of the systems.

In the Production department, mobile scanning systems make it possible to order all hydraulic components in a matter of seconds. Whether customer-specific assembly kits or kanban shelves, depending on requirements, the exact processes needed to offer customers the best added value are in place.

In the spare parts business, HANSA-FLEX impresses with its fast response times and outstanding availability. More than 100,000 hydraulic products can be selected at all times. With the unique network of 400 branch offices and the 24 x 7 mobile rapid hydraulic service, customer needs can be quickly met at any time, any place. Its online services also give HANSA-FLEX great

customer proximity. The online shop can be used by customers to conveniently procure materials, without having to make any compromises. The online shop offers customers the same levels of product quality and diversity that they have enjoyed from the HANSA-FLEX branch offices for over 50 years now.

The app offers the quickest connection to the mobile rapid hydraulic service. If a hose line fails, customers can share their location, photos of the damage and the hose line code with just a few clicks. This ensures that HANSA-FLEX service engineers are optimally prepared even when making initial contact and always show up at repair sites with the right spare parts.

The My.HANSA-FLEX customer portal sets new standards in hose line management through the use of the X-CODE. All information is centrally recorded and can be accessed within seconds. The database contains details such as the installation site, machine type as well as replacement-related parameters and wear and tear categories. A clear dashboard makes it easy to see all the key information at a glance. With direct contact to the HANSA-FLEX service engineers, preventative maintenance is now simpler than ever.

HAWE Hydraulik develops and builds hydraulic components and solutions for many segments in the mechanical and plant engineering industry. The scope of services offered ranges from consultation, project management and comprehensive documentation through to the construction of prototypes. The company's factories are structured to manufacture and assemble products in large unit numbers as well as in lot sizes of one piece.



For a world under pressure



The family-run company was founded in 1949, has its headquarters in Munich with seven more production sites as well as five sales offices in Germany and 14 international subsidiaries.

The 30 sales partners in countries around the globe provide sales and marketing support worldwide.

The modular product portfolio comprises fixed and variable displacement pumps, hydraulic power packs and pumps, valves, cylinders and hydraulic accessories as well as electronic components. As all of the pressurised components are made from steel, they can operate at pressures of up to 700 bars. This in turn renders applications in the mid-pressure ranges particularly long-lasting and safe.

Applications such as the clamping functions of machining tools reap the benefits of the high power density and compact built of HAWE components, as they bring down the machines' total lifetime costs and energy uptake. In addition, the reliability and straightforward maintenance of

HAWE components pay off, especially in wind energy and solar power plants.

The solutions developed for mobile machines in construction equipment, cranes, drilling, agriculture and forestry machines enable the user to control the hydraulic consumers very precisely and independent of the load. CAN-BUS interfaces simplify the actuation of more complex systems. Intelligently controlled axial piston pumps ensure efficient use of energy and thereby support compliance with exhaust emission standards.

Providing sustainable solutions is integral part of HAWE Hydraulik's entrepreneurial responsibility, as is borne out by many small and large-scale activities undertaken by the company. Thus, internally the company consistently implements certified environmental and energy management as well as health and safety systems. Since 2011 HAWE Hydraulik has been a member of the United Nation's initiative 'Global Compact'. It is its proven commitment to respect human rights and labour standards and to work for environmental protection and fight corruption.



HIWIN is renowned the world over for high-quality drive technology. The product range includes:

HIWIN – We live motion.

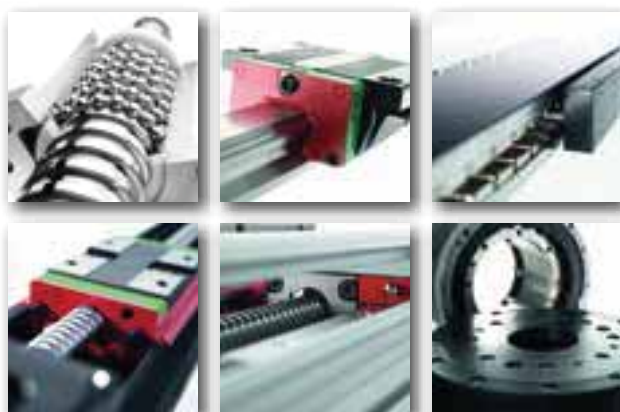

Linear guideways

HIWIN linear guideways are characterised by high guidance accuracy, ease of assembly and lubrication and a long service life.

Ballscrews

HIWIN ballscrews provide impressive, low-friction and precise running. They only require a low torque and are very rigid.

Linear motors

HIWIN linear motors are of increasing importance in highly dynamic movements. This design converts electrical energy directly into a linear movement.

Linear modules

HIWIN linear modules are complete positioning units, which combine a ballscrew and linear guide in one rigid substructure. The motor and/or gearbox is flange-mounted directly on the linear module.

Rotary tables

HIWIN rotary tables can be used in many different ways thanks to their clearance-free and rigid structure and compact design.

**Fluid technology, hydraulics, electronics and service.
Worldwide.**



Wherever fluid technology combined with electronics and engineering are needed, Hydac is there.

With over 7,500 employees, 48 overseas companies and over 500 sales partners worldwide, we provide engineering consulting services, delivery and service right where our customers are.

Delivery program:

Components, sub-systems and complete systems for hydraulics, fluid technology, process technology and environmental technology.

Focus: filters for fluid technology, filters for process technology, fluid service, storage technology, compact hydraulics (cartridge valves, control blocks, compact power units).

Energy efficiency is an important step towards greater sustainability in stationary and mobile technology. HYDAC provides products and solutions for this, which extend fluid lifetimes and ensure the optimisation of new and existing systems.

Other product areas:

fittings, pumps and power unit accessories, electronics and measurement equipment, electronic control technology, solenoid technology, mounting technology, cylinder and systems technology, hybrid technology, Condition Monitoring, Kinesys variable-speed drives, fluid engineering, engineering support. Our own training centre with e-learning platform, and the FluidCareCenter for research and development.

Range of services

With numerous service support points around the world, HYDAC offers a comprehensive range of services for hydraulics.

- Inspection service
- Maintenance service
- Repair service
- Installation service
- Optimisation service

Sales organisation

Sales of Hydac products is done via company-owned sales and service affiliates with distribution centres and via sales and service partners around the world. With locally-based competence, we are able to take care of customer needs in the areas of engineering and manufacturing in many national markets.

Applications

Our wide range of products are used in construction machines, agricultural equipment, machine tools, plastics machinery, hydraulic and mechanical presses, the iron and steel industries, power plants, wind energy plants, process technology, marine/offshore technology, the paper industry, the aerospace industry and the automobile industry.

Company philosophy

All areas of the company are oriented to the demands of the global marketplace. Quality, competitive pricing, reliable delivery, service, consulting, innovation, technological orientation, sustainability, and closeness to customers are the basis for our actions as a company.

Together with customers, engineers from HYDAC develop innovative and cost-effective solutions, a method which has proven itself many times, and for which HYDAC has the necessary resources and technological expertise.

A cooperative exchange of expertise is the key to a successful future for our customers and for HYDAC.



Frequency-controlled compact power unit in combination with height/length linkage as an intelligent control logic for machine tools.



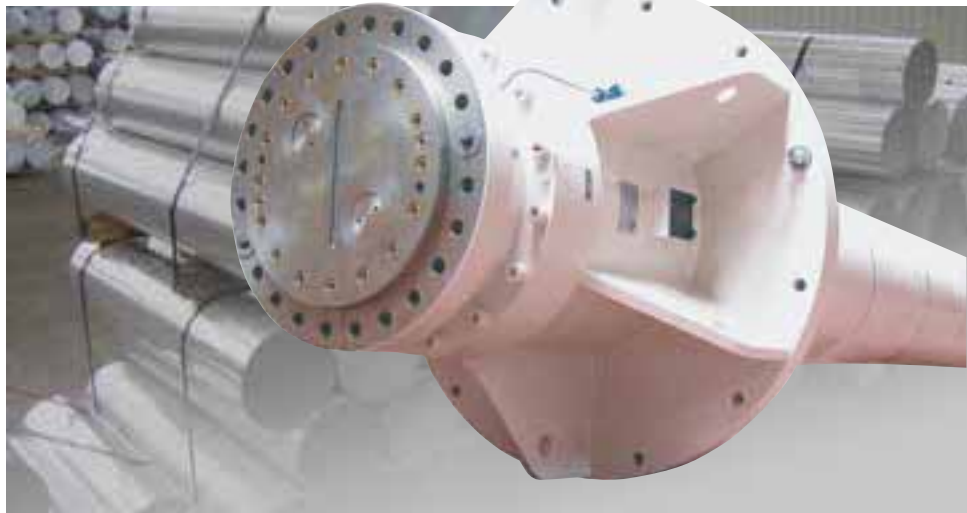

The Hunger Hydraulic Group of Companies – Your Partner for Complete System Solutions



The Hunger Hydraulic Group, trading internationally in the metal and capital goods industries, is one of the leading manufacturers in the field of hydraulic engineering. For more than 60 years the company has been dedicated to providing solutions in hydraulic and automotive engineering.

Corresponding to growing customer requirements, the Hunger Hydraulic group of companies has diversified its product range, and is represented by 14 companies in seven countries.

Thanks to the cooperation of the specialised companies in the Group, the customer can now procure custom-made complete solutions which fulfil their maximum requirements, even in extremely demanding applications.

Hunger systems are employed worldwide in various applications, such as steel presses and mills, aluminium casting plants, offshore, hydroelectric dam projects, bridge constructions, open-pit mining, machine-tool manufacture, test bed engineering, renewable energies, building machinery,

fire-fighting equipment, environmental technology, trucks and large mobile cranes as well as air and spacecraft.

Range of Products

Hydraulics:

Hydraulics is the main business segment of the Group.

- Hydraulic cylinders (special, standard and telescopic cylinders)
- Surface coatings: Ceraplate, Ultraplate, Chrome
- Seals and bearing elements
- Spherical plain bearings and rod ends
- Rotary distributors and rotary actuators
- Hydraulic valves
- Hydraulic power packs
- Abrasives: honing stones and tools
- Commissioning and repair services
- Engineering and system development

Automotives:

- Fifth-wheel and trailer couplings
- Sheet metal processing: formed and punched parts



Quality and product diversity worldwide

As a leading supplier of PN sensors to industry, the ifm group of companies is well known for its quality and product diversity worldwide, with more than 5,200 employees in over 70 countries and more than 115,000 customers. The success story of the family-owned company began in 1969 with the invention of inductive sensors.

Ever since then, highest quality standards have been applied to both the wide product portfolio and customer-specific solutions. You can find ifm sensors and system solutions in almost all industries. Two successful examples from fluid technology are the PN7 pressure sensor and the TD pressure transmitter.

After 20 years of successful product history, the new generation of PN sensors from ifm has been launched. Thanks to the programmable red/green display it is possible, for example, to represent operating areas. Moreover, the new PN is simple to use with three-button operation, optimum alignment by rotating the process connection, high overload protection, IP67

compliance, and captive laser labelling. In short: the new PN will be your perfect partner for many years, even in the harshest of environments.

The TD – the first temperature transmitter with display and IO-Link – is another successful ifm development for fluid applications. Thanks to the bright 4-digit LED display and IO-Link the temperature transmitter indicates exactly what it can actually do. Furthermore, the temperature transmitter is distinguished by a compact, hygienic design with integrated Tri-clamp and G1/2" process adapter. This allows quick and easy installation. Usually, no complex set-up is required because the transmitters are supplied with a pre-scaled measuring range. Nevertheless user-friendly configuration is possible via IO-Link. The fast response time $T_{05/09} = 1/3$ s and the different probe lengths starting from 30 up to 250 mm are two other advantages of the TD temperature transmitter.





Made for Motion

Being a powerful manufacturer of industrial applications in Power Transmission, KTR supplies high-quality drive components, brake systems as well as cooling systems and hydraulic components to the industrial markets of all five continents.

KTR is a pioneer and innovator in coupling technology and has become a very important party in Power Transmission over the last 50 years, with a high level of technological competence. The KTR product portfolio includes mechanical couplings and torque limiters having multiple features and various designs, clamping sets and precision joints for a variety of uses in Power Transmission.

The company is the only manufacturer worldwide providing two different brake systems based on different operating principles: hydraulic and electromechanical. The customer has the choice and is always provided with individual and tailor-made systems. No matter where they are used – above ground or below ground, onshore or offshore – KTR brake systems are universally applicable, doing a reliable job in various industries.

KTR cooling systems are used in stationary and mobile hydraulics, providing cooling for water, charge air or fuel, hydraulic and lubricating oil. They can be accurately selected for the specific application either according to the catalogue or in consultation with the customer.

Hydraulics has always been a vital part of KTR's core business. The manifold product portfolio of hydraulic components comprising bellhousings, foot flanges, damping elements, steel and aluminium tanks as well as temperature probes and tank heaters. Special sizes and customised products are included here, too.





Lenze



As a global specialist in Motion Centric Automation, we offer you products, drive solutions, complete automation systems, engineering services and tools from a single source. As one of the few suppliers in the market, Lenze supports its customers (mechanical engineering) in all phases of the engineering process – from the initial idea to aftersales, from the control system all the way to the drive shaft. A global network of sales and application engineers supports customers in developing end-to-end drive and automation solutions that facilitate the implementation, production and service of their machine.

With 65 years of experience in the market, Lenze has a comprehensive machine know-how which flows into the individual machine concepts. A product range tailored to the machine application, ease of use of the products, appropriate engineering tools and services, well-designed industry solutions and standardised software modules allow customers to focus

on their own core competencies and the special features of their machine and thus strengthen their competitive edge.

The company is headquartered in Aerzen near Hamelin. The operational units are designed as flexible medium-sized businesses, making decision-making processes short, structures as easy as possible and ensuring that our solutions are always focused on the customer. With our motivated and committed approach, we work together with our customers to create the best possible solution and set ideas in motion – regardless of whether you are looking to optimise an existing machine or develop a new one.

Lenze employs approx. 3,400 people in 53 subsidiaries worldwide. The group is represented in 60 countries, on all continents, with its own sales companies, research and development sites, production facilities and logistics centres, as well as a wide network of sales and service partners.



Lenze

Lenze SE • PO Box 10 13 52 • 31763 Hameln • Germany
Phone +49 5154 82-0 • E-Mail E-Mail Lenze@Lenze.de
Internet www.Lenze.com

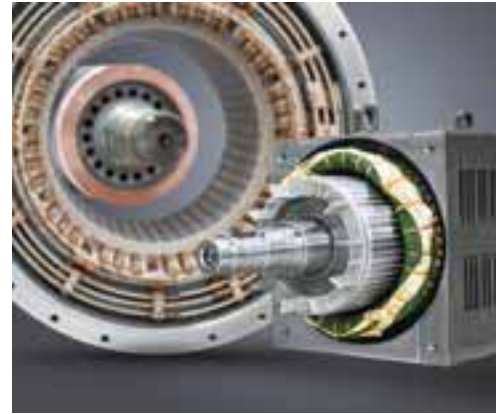

Sales China:
Liebherr Machinery Service (Shanghai) Co., Ltd.
Building No. 1, 88 Maji Road, Waigaoqiao Free Trade
Zone, Shanghai 200131, P.R. China
Phone +86 21 2893 8039
E-Mail components.china@liebherr.com

Sales USA:
Liebherr Components North America Co.
1465 Woodland Drive, Saline, MI 48176, USA
Phone +01 734 944 5941
E-Mail info.lcn@liebherr.com

Sales Russia:
OOO Liebherr-Russland Bolschoj Palaschewskij
Per. 13, Bau 2, 123104 Moscow, Russia
Phone +07 495 280 18 94
E-Mail info.components.lru@liebherr.com

System-engineered components

The product areas of Liebherr-Component Technologies AG: diesel engines, gas engines, Common Rail fuel injection systems, hydraulic pumps and motors, hydraulic cylinders, planetary drives and winches, large diameter bearings, electric machines, power electronics, electronics, switchgear, remanufacturing.

Liebherr-Component Technologies AG is responsible for all activities involving the components sector within the Liebherr Group. The companies and corporate units belonging to this sector are specialised in the development, design, production and remanufacturing of high performance components in the field of mechanical, hydraulic and electrical drives as well as control technology. These products are developed and produced at eight plants in Germany, France, Switzerland, China and Mexico.

Top quality for every application

The wide range of Liebherr components includes diesel and gas engines, Common Rail fuel injection systems, hydraulic pumps and motors in axial piston design, hydraulic cylinders, large diameter bearings, planetary gearboxes and winches, electrical machines, as well as electric and electronic controls and components. Parts and systems developed by Liebherr are particularly tough, and work safe and reliable in even the most extreme environmental conditions such as heat and dust, or maritime environments.

For more than 60 years Liebherr has stood for sophisticated, practical products and services in a diverse range of technological fields: Today, with more than 130 companies and over 39.000 employees on all continents, the Group is one of the world's largest manufacturers of construction machinery. Components and systems fabricated by Liebherr are not only used within the Group's applications, other manufacturers also integrate them in their own machines. For example, in wind turbines, maritime applications, in cranes, construction and mining equipment, agricultural machines or in decentral energy systems.

Highlights of the product range are the 12 cylinder V-diesel engines of up to 750 kW, mining cylinders with 5.000 mm stroke length, single-piece large diameter bearings of 6.000 mm diameter, heavy-duty rope winches with an output torque of 2.500.000 Nm or complete electronic systems for machine operation.

From single components to complete system solutions

Liebherr is able to design both the complete diesel-hydraulic and diesel-electric drive trains of mobile machinery. Depending on the requirement, individual components from the broad product selection can be extended up to the complete drive train. This creates system solutions with real conviction, which can be integrated into a whole range of applications.

A high degree of vertical integration and the use of flexible, state-of-the-art production systems allow Liebherr to offer its customers tailor-made solutions.

Lifecycle-Management

For the mechanical and hydraulic drive train components, Liebherr offers reconditioning in different stages from a specialised works – starting from repairs up to a complete remanufacturing in the quality of new parts.

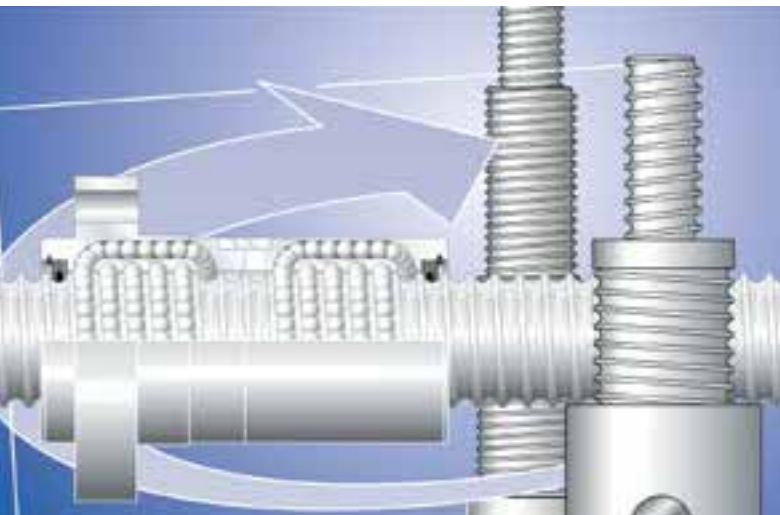

Ball screws: Your gain – marketing success
 You will succeed in increasing the operating security and performance of your machines using AM ball screws. They are the pace setters in high speed: up to $n \times d = 235,000$ $v = 150$ m/min and faster, perfect in dynamic and running quality – also **telescopic ball screws** and **high-load ball screws** with up to dia. 160 mm for load capacities up to 500 kN.

Boring Spindle Assemblies: Your gain – high speed and accuracy
 Boring mills of the new generation work with high speed, up to 5,000 rpm. Our manufacturing techniques in boring spindle assemblies will ensure that your profit from highest balancing qualities enabling quiet and most accurate operation. We have developed some special production measures against heat influence. For rams up to about 5,000 mm length we have special know-how for the inside grinding of bearing seats with narrowest tolerances.

Our specialities – highlights in manufacturing engineering

Your gain – quality and profitability
 Internationally successful mechanical engineering companies benefit from our long years of experience. Our know-how in manufacturing technology guarantees top quality, high accuracy, economic efficiency and profitability.

Our products – tailored to your needs

Our efficiency is concentrated on machine components of high precision and wear resistance – one-off-parts, units and series of all dimensions in lengths up to 15,000 mm in one piece are manufactured completely in our own workshops, individually according to your drawings, ready-for-installation.

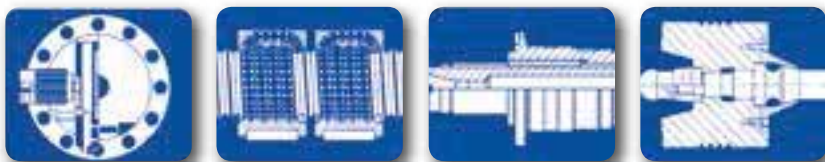

We are your competent partner for special solutions!

For machine tools, general engineering:

Boring and milling spindles, complete main spindle assemblies with rams, ball screws, telescopic screws, quills, spline shafts, threaded spindles, driving shafts, knife shafts, pressure spindles, piston rods, compressor shafts, control shafts for heavy Diesel engines ...

mayr® power transmission, with approximately 550 employees working at the Mauerstetten headquarters, develops and manufactures a wide range of products centred around mechanical and electrical power transmission. This range of products includes backlash-free shaft misalignment compensation couplings, torque limiting clutches, electromagnetic clutches and brakes, as well as safety brakes and high-quality DC drives. The company is a worldwide market leader torque limiting clutches, elevator brakes, stage brakes and safety brakes for gravity-loaded axes.



Your reliable Partner

We at mayr®, are well known for our innovative and economic solutions, setting the standards for power transmission all over the world. Our uncompromising commitment to quality, combined with close co-operation with our customers, is the secret of our success. Qualified engineers equipped with the most modern resources in the design and development departments to offer the most effective solutions to our customers.

With eight sales offices in Germany, eight subsidiaries in France, Switzerland, Italy, the USA, England, Poland, Singapore and China as well as approximately 30 additional representatives in other countries, mayr® power transmission is considered one of the top companies for power transmission in all the important industrial regions worldwide.

Backlash-free torque limiting clutches in filling-equipment and packing-machines

Overload damage in production machines costs time and money. In the case of collisions at high speeds, mechanical safety clutches are significantly faster than the integrated safety functions of drive controls. The backlash-free EAS®-clutch will have already disconnected the damaging energy in the drive system and prevented damage even before the control device can even react to the overload.

Reliable safety brakes for stage technology

Safety brakes for theatre, film and stage equipment are subject to strict technical requirements. They have to hold the suspended loads reliably and must brake the movement safely in case of emergency stop or power failure – to protect both the people and the material. The maintenance-free, easy-to-install ROBA-stop®-silenzio® brakes by mayr® power transmission are the quietest safety brakes on the market – even after several hundred thousand switching operations.



Moog – High-Performance Motion Control Solutions



Moog Servo Drives



Moog Radial Piston Pumps



Moog Servo Motors

Moog's Industrial Group, a division of Moog Inc., designs and manufactures high performance motion control solutions combining electric, hydraulic and hybrid technologies with expert consultative support in a range of applications including energy production and generation machinery, industrial production machinery and simulation and test equipment.

With operations in more than 26 countries, Moog delivers a high level of service, support and collaborative expertise tailored to the requirements of machine builders and design engineers worldwide.

MOOG

Moog GmbH • Hanns-Klemm-Str. 28 • 71034 Böblingen • Germany
Phone +49 7031 622-0 • E-Mail info.germany@moog.com
Internet www.moog.com/industrial

High Pressure, Special Fluids



Oilgear's strength lies in its extensive axial piston pump portfolio and its experience in applications for high flow rates and sophisticated system solutions.

Oilgear axial piston pumps are suitable for versatile and demanding applications in industrial engineering, as well as in mobile applications. In addition, Oilgear has been supplying customized drive solutions and controls for all areas of mechanical engineering. This includes hydraulic drives for extrusion and forging presses as well as test systems for hydraulic components and vehicle safety. Oilgear designs and assembles these systems and puts them into operation on site. Oilgear's service team supports its customers throughout the world in the efficient operation of these applications.

Oilgear

Oilgear Towler GmbH • Im Gotthelf 8 • 65795 Hattersheim • Germany
Phone +49 6145-3770 • E-Mail info@oilgear.de
Internet www.oilgear.de

Whether in harsh industrial or mobile hydraulics applications, Temposonics® position sensors—integrated in hydraulic cylinders—are the ideal solution for high-precision, dynamic and reliable linear measurement.

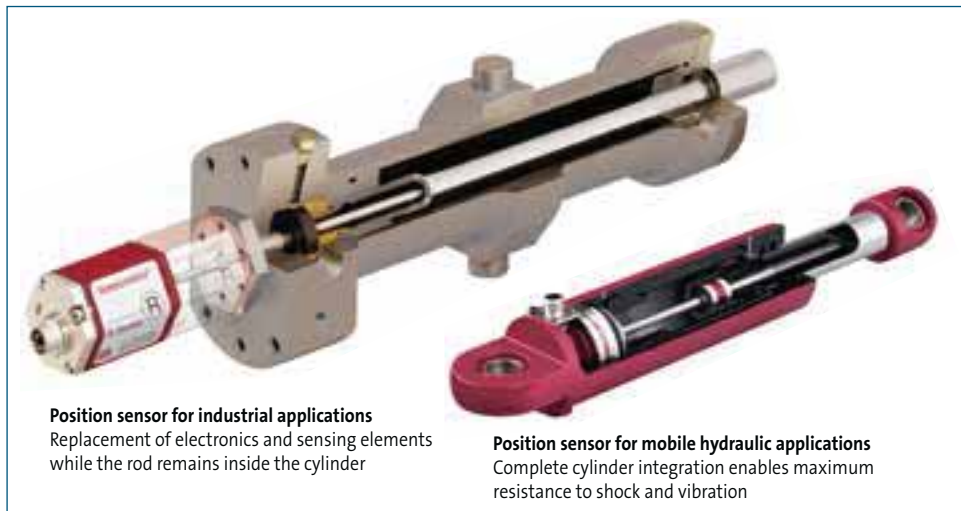

Position sensor for industrial applications
Replacement of electronics and sensing elements while the rod remains inside the cylinder

Position sensor for mobile hydraulic applications
Complete cylinder integration enables maximum resistance to shock and vibration

Absolute Position Sensors for Cylinder Integration



SSI, Profibus, EtherCAT, EtherNet/IP, Profinet, Powerlink). Temperature stability, resistance to shock and vibration as well as electromagnetic compatibility are among the reasons why Temposonics® sensors are the first choice.

Easy Replacement due to Modular Design

The innovative modular design of the R- and G-Series allows easy replacement of sensing element and electronics without breaking the cylinder's high-pressure seal, significantly reducing maintenance costs and downtime. The sensor's stainless steel rod becomes part of the cylinder, while the electronic head and the sensing element can be removed quickly and separately. This is another reason why customers have trusted in Temposonics® sensors for decades.

Absolute, Non-contact Measuring Principle

Thanks to the magnetostrictive principle, Temposonics® sensors detect positions contactless and wear-free. The absolute measurement technology ensures that the sensors are ready for operation immediately after start-up or downtime. The high-performance sensor electronics provide an output signal with a high signal-to-noise ratio. They are extremely robust and available in different designs, large measuring range (from 25 mm to 20 m) and various interfaces (analog, CANbus, CANopen,



Parker provides the broadest range of drive and fluid technology products available from any single supplier. As a problem solver, Parker offers customised systems, innovative components, global distribution and full service that combine global availability with regional presence.



ENGINEERING YOUR SUCCESS.



Parker Hannifin, the world's leading diversified manufacturer of motion and control technologies and systems, has been a market leader in the motion, drive and fluid technology market since years.

With its expertise in nine major technologies, namely hydraulics, pneumatics, electromechanics, filtration, process control, fluid and gas handling, sealing and shielding, climate control and aerospace, Parker serves over 450,000 customers in more than 1,000 markets. Filters, hoses, fittings, valves, vessels, pumps, motors, drives, electronics, controls, cylinders and seals – Parker offers these precision-engineered solutions for a wide variety of mobile and industrial applications.

Through its innovative components and systems, Parker enhances productivity in the interest of its customers, without losing sight of the demands of environmental protection and sustainability. Energy can be saved in nearly every industrial

process. With energy-efficient hydraulic drives, for instance, Parker has demonstrated energy savings to the tune of 40% and reduction in CO₂ emissions in press technology through its frequency-controlled hydraulic drives.

In addition to high-quality components and systems, Parker offers premier customer service. With comprehensive know-how and a unique network of distributors and ParkerStores worldwide, Parker supports its customers in all stages of a project and guarantees individual and market-oriented system solutions with state-of-the-art-technologies. This is based on a partnership concept that enables the customer to work profitably anywhere, at any time.

The central contact point for the user is the Parker Sales Company in Kaarst, Germany. All activities around the supply of components and systems, as well as maintenance, assembly and commissioning on-site are centrally coordinated there.



PIV Drives is a worldwide renowned producer of complete power transmission solutions and mechanical gear units for industrial applications. Founded in Germany 1928, we develop and produce reliable high quality and high performance power transmission solutions with a long service life. Whether standard gearboxes or special solutions, we bring Made in Germany to life and satisfy our customers by delivering innovative and high performing products. As part of the Brevini Group we benefit from the Group's powerful worldwide sales and service network. Our slogan: Never let a customer down!



Smart Solutions – Your Global Partner for Gearboxes and Complete Drive Packages



PIV and Brevini Power Transmission together offer a complete product portfolio, ranging from helical and bevel helical gearboxes to planetary gearboxes, from special products, such as single- and twin-screw extruder drives, to winches.

Our gearboxes are used in almost all industries in industrial and mobile applications: in steel and metal machining, material handling, mining, logistics and port cranes, cement factories, machines for the plastics and rubber industry as well as renewable energies.

„The core of our business is not only to produce gearboxes. It's to develop the best solution for our customer.“

Since 2001, PIV Drives is part of Brevini Power Transmission. The Group is among the world's top five manufacturers in the sector of mechanical power transmission and gear drives.

Even for the most demanding power transmission needs, we have the right solution for You
Innovative solutions are one of the main reasons for the growing success of the Group. With our solutions for mining, material handling, cranes and for the rubber and plastics industry, PIV Drives is among the market leaders. Our philosophy: to find the right solution we work closely with our customers.

Our most successful products are: the POSITWIN series for twin-screw extruder drives (since 1985), the POSIRE2 series of helical and bevel helical gearboxes (since 1995) and the new POSIRE2 ADVANCED series for high efficiency drives, which was internationally launched on the market in 2013 with our new conveyor drive.

With 26 subsidiaries and numerous distributors of the Brevini Group, PIV Drives is represented in the major global markets.

The Brevini Group has over 2,400 employees and generates a turnover of more than 420 Million Euros and continues to grow.



PIV Drives GmbH • A company of Brevini Power Transmission
Justus-von-Liebig-Str. 3 • 61352 Bad Homburg • Germany
Phone +49 6172 102-0 • E-Mail info@piv-drives.com
Internet www.piv-drives.com

In 1873, RENK was founded in Augsburg as mechanical workshop to manufacture any type of gears. Therefore the enterprise can look back on more than 140 years of experience and own development work in propulsion technology. Since 1923, RENK Aktiengesellschaft is a member of MAN group, one of the leading European offerers of capital goods.



Our metier: propulsion technology



Today RENK is one of the worldwide acknowledged manufacturers of high-quality special gears, components of propulsion technology and test systems. RENK products excel by highest precision and reliability as well as excellent quality. Experience and creativity in development, design and manufacture guarantee RENK products a top position on the international market.

Production takes place at three plants in Germany as well as at associated companies in France, Switzerland and in the USA.

RENK is divided into four independent strategic company divisions:

Vehicle transmissions

Comprise the vehicle transmission division at the Augsburg plant and the French affiliated company RENK FRANCE S.A.S. RENK is the leading manufacturer of tracked vehicle transmissions worldwide. Moreover, the Augsburg-based associated company RENK Test System GmbH manufactures testing rigs. The company develops and builds ready-to-key test systems for devel-

opment, manufacture and quality assurance of products of automotive, railways and aircraft industry.

Bearings

This business unit produces slide bearings as well as flexible couplings at the Hannover plant. RENK is also worldwide leading on the sector of electric machine bearings.

Special gear units (Industrial and marine gear units)

The Augsburg plant is focused on the construction of special bull gears for marine and specific stationary applications whose performances reach values up to 140 MW and torques up to 15 million Nm.

Standard gear units (Industrial and marine gear units, gear units for wind power stations, couplings)

The Rheine plant is specialized in the product ranges of general industrial and large marine gear units as well as in couplings of all design types. In addition RENK produces multi-megawatt gear units for offshore wind plants.





RINGSPANN GmbH

Innovative achievements have made RINGSPANN one of the leading suppliers of Power Transmission, Workholding Technology and Remote Control Technology.

RINGSPANN customers include some of the most important international manufacturers of machine tools and systems as well as the aerospace industry.

From our headquarter in Bad Homburg, Germany, and from a worldwide network of subsidiaries and agencies, we ensure personal on-site service. Production and assembly plants in various countries provide rapid, reliable delivery.

With more than 70 years of experience in research and design, RINGSPANN is a specialist in Power Transmission Components, Precision Clamping Fixtures and RCS-Remote Control Systems. Professional application engineering guarantees RINGSPANN customers optimum technical and economical solutions in the following product-fields:

- Freewheels
- Brakes
- Shaft-Hub-Connections
- Overload Clutches
- Couplings
- Precision Clamping Fixtures
- RCS® Remote Control Systems

RINGSPANN is totally committed in our Corporate Policy to customer service, both now and in the future.



RINGSPANN®

RINGSPANN GmbH • Schaberweg 30-38 • 61348 Bad Homburg • Germany
Phone +49 6172 275-0 • E-Mail info@ringspann.com
Internet www.ringspann.com

High-Performance and Efficiency: Rolling bearings and linear guidance systems from Schaeffler for over 60 industrial sectors





The Industrial division of the Schaeffler Group supplies rolling and plain bearings, linear technology, maintenance products, monitoring systems and direct drive technology to customers from over 60 different industrial sectors.

The mobility sector develops rolling bearings and power transmission solutions for bicycles and motorcycles as well as for rail vehicles and agricultural and construction machinery. Schaeffler offers bearing solutions for all types of drives, whether mechanical, electric or hydraulic. Thanks to its application-specific engineering expertise, Schaeffler covers both mobile and stationary drives for all industrial applications.

Renewable energies are a strategic growth area where Schaeffler positioned itself early on. Schaeffler has developed and produced bearing supports for wind turbines for over 30 years. Schaeffler is also a respected development partner and supplier for applications in conventional water power and tidal stream and wave power, as well as for precise solar tracking.

In the extraction and processing of raw materials, Schaeffler also supplies all leading manufacturers and operators in the sectors oil and gas, mining, paper and metal production.

Schaeffler has been an innovative systems partner for the development of medical technology and production machinery for several decades. This

applies to machine tools and machinery for the textile, printing, as well as the food and packaging industries. The focus is always on optimizing the entire system. The combination of component, system and application expertise is a particular strength of Schaeffler, especially for the development of products for future, self-optimizing machine tools within the context of Industry 4.0.

The portfolio for linear technology includes both mechanical components such as linear actuators and linear tables (as well as multi-axis linear modules created using these), mechatronic systems and individual system solutions.

FAG Aerospace is the leading development partner and supplier worldwide for special rolling bearings for the aerospace industry. The product portfolio ranges from main shaft and gearbox bearing supports in aircraft engines and gearbox and rotor pylon bearing supports in helicopters to turbo-pump bearings in rocket engines as well as special bearing supports for satellites and spacecraft.

Schaeffler Industrial Aftermarket is responsible for the replacement parts and service business for end customers and sales partners in all major industrial sectors. Schaeffler Industrial Aftermarket reduces maintenance and operating costs, increases machine availability, and thus boosts its customers' business success through comprehensive, innovative solutions, products, and services for rolling and plain bearings, as well as by consistently applying the total cost of ownership philosophy (TCO).



Market leader through high technology



Worldwide, ROEMHELD is now considered to be the market leader in the field of hydraulic power workholding for metal-cutting production engineering. With expertise in this field and backed by a team of around 300 employees at the location Laubach, Germany, ROEMHELD has a strong business base to realise high technology.

Due to the intensive development work, which we undertake partially in close cooperation with customers and partners, we are in a position to not only meet the continuously increasing demands of the market, but also to influence the market development through our futuristic innovations.

The wide product range of the ROEMHELD Group from its three sites in Laubach and Hilchenbach in Germany and Götzis in Austria, consists of around 16,000 catalogue items.



ROEMHELD
HILMA ■ STARK

Römheld GmbH, Friedrichshütte • Römheldstr. 1-5 • 35321 Laubach • Germany
Phone +49 6405 89-0 • E-Mail info@roemheld.de
Internet www.roemheld-gruppe.de

TRIES ... the top address for innovative solutions



TRIES in Ehingen has been developing and producing hydraulic elements since 1964. Innovative technologies, reliable quality as well as partnerships and collaborations with our customers allow us to produce creative solutions of high complexity.

Our development engineers always strive for more and never settle for second-best solutions. This is also part of the TRIES company philosophy. We adopt this attitude when supporting and advising our customers, and we naturally encourage our employees and trainees to share this idea. This has made us into one of

the leading suppliers of hydraulic elements. TRIES' hydraulic elements and control units are used worldwide in all engineering sectors.

We believe that high-quality products and protection of the environment for our customers will secure the future of our company.

It goes without saying that we always comply with the applicable standards, regulations and laws.



TRIES GmbH & Co. KG • Hydraulik-Elemente Ehingen
Röntgenstr. 10 • 89584 Ehingen • Germany
Phone +49 7391 5809-0 • E-Mail info@tries.de
Internet www.tries.de

SEW-EURODRIVE is movement, tradition, innovation, quality, and service all in one. We prove this to our customers every day and have done so for more than 80 years. We do not just move countless conveyer belts, bottling plants, sports stadium roofs, gravel plants, assembly lines or even you on escalators. We also are moving ourselves. In our company, there is no such thing as standing still. Collectively, more than 16,000 employees around the world are moving to develop solutions that help you optimise your processes. This is how SEW-EURODRIVE has evolved throughout its history to become the market leader in the industry of drive automation with a turnover of more than EUR 2.5 billion.



We provide movement.



The movement you need is created with various product solutions and drive systems. According to customer or industry needs, SEW-EURODRIVE offers individual solutions using our comprehensive modular system for building gearmotors and frequency inverters, servo drive systems, decentralised drive systems, and industrial gear units.

The individual drive system, custom to your tasks

If you want to be successful, you have to know the tasks and processes of your customers and industries. This is why SEW-EURODRIVE looks beyond the borders of drive engineering to find the solution perfect for you. With an oftentimes unconventional way of viewing and approaching things, we have been setting the trends and standards in drive engineering for years. In this way, “engineered and made by SEW” has become a seal of quality in the world of drive engineering.

The solution for your task tomorrow exists today at SEW-EURODRIVE. With our universal modular concept of gearmotors, control systems, software, service, and extensive accessories, the foundation is already in place to fulfill your requirements comprehensively and as quickly as possible. The uncompromising quality of our market-oriented products, all developed and constructed at our own plants, are the pillars of our commercial success.

“People don’t want products, they want solutions.” True to this motto, SEW-EURODRIVE not only develops and produces gearmotors in-house but also supplies the customised electronic solutions for these components. Only if the control systems are perfectly matched to the drives will there be an optimum flow. This setup gives developers, designers and planners of systems and projects the drive solutions from one source that let you efficiently control individual motion sequences or entire processes.

SKF offers more than just bearings: Five platforms for outstanding customer value



Radial shaft seals from SKF combine low friction with excellent sealing properties.

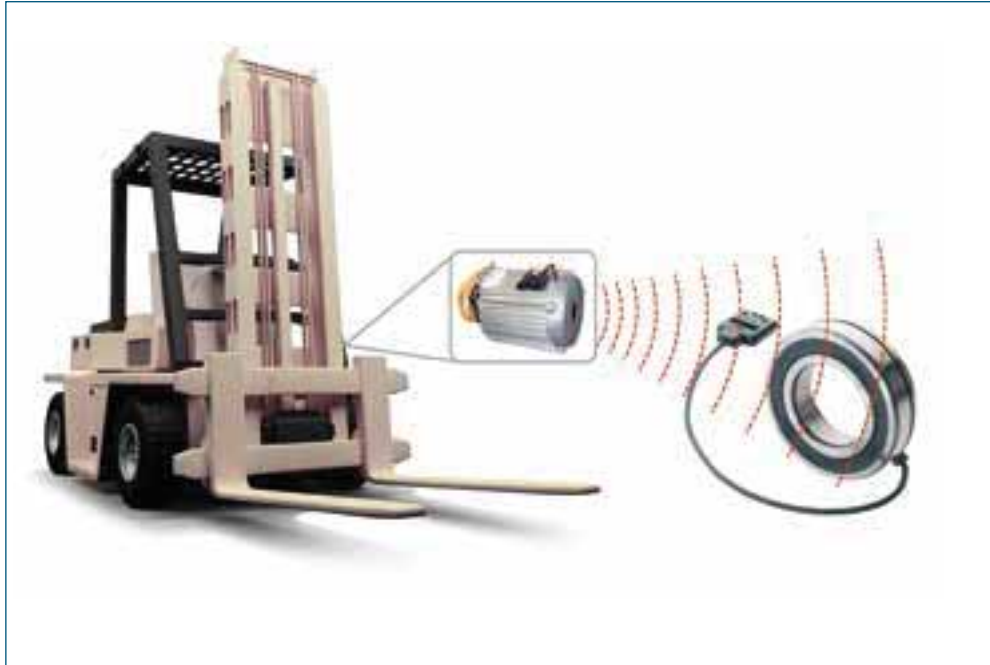

Mechatronics from SKF increase efficiency in a variety of application areas. A sensor bearing with EMC filter for protecting fork-lift trucks.

Since its foundation SKF has continued to push the boundaries of technical limits. As a technology pioneer SKF now offers solutions of five areas of expertise: Bearings, units, seals, lubrication systems, mechatronics and services.

Since 1907 SKF has combined technical progress with in-depth application know-how and on this basis developed innovative, market-oriented products and services.

Added value through SKF bearings

Because a bearing can only work perfectly when the dynamic interplay of all of the components is optimised, SKF carries out intensive basic research – from material science to process technology. The results of this research include the “enriched” heat treatment: as a result of this process for example the cylindrical roller thrust bearings in axial piston motors of mobile hydraulics systems can withstand even most unfavourable operating conditions.

Another example of the particular added value of SKF bearings are “high-capacity” cylindrical roller bearings: a special cage design gives the bearing a significantly higher carrying capacity. For electric motors and generators SKF offers hybrid bearings with steel rings and silicon nitride rolling elements. This prevents the flow of electrical current and though damage of the bearings and increases the service life compared with a standard steel bearing of the same dimensions.



The services offered by SKF range from worldwide monitoring of more than 700,000 systems all over the world to calculating and simulating of individual bearing designs.

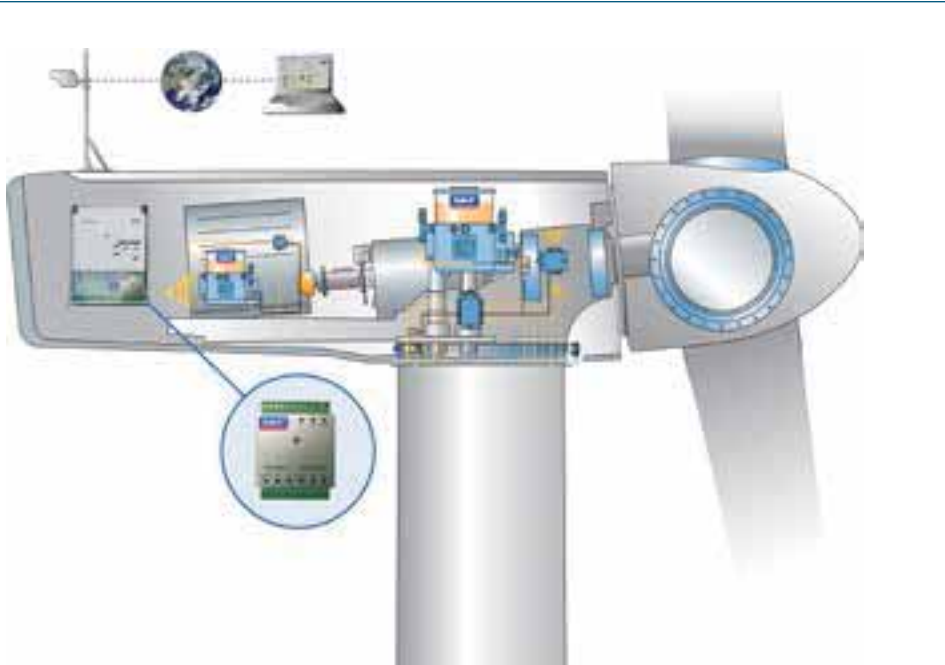

More and more “intelligent” lubrication systems from SKF also reduce the overall operating costs of wind turbines.

SKF is a global leading provider of rolling bearings, seals, mechatronics components and lubrication systems with extensive services in the areas of Engineering, Maintenance and Servicing and Training. SKF has a presence in more than 130 countries worldwide and cooperates with around 15,000 authorised distributors. The turnover of the Group in 2014 was SEK 70975 million. The number of employees was 48.593. More information at www.skf.com

Added value through SKF seals

Faulty seals can cause a breakdown of entire machines. SKF offers a range of radial shaft seals incorporating the combined knowledge of bearing and seal experts.

Added value through SKF lubrication systems

SKF offers highly sophisticated lubrication systems. These more and more intelligent systems are suitable for innumerable applications. Through the acquisition of Vogel Lubrication Systems and Lincoln, SKF now has the largest lubrication system portfolio in the world.

Added value through SKF services

SKF customers can rely on comprehensive condition monitoring services to monitor effectively conditions of systems remotely. These include for example Asset Diagnostic Services, a cloud-based

system which SKF experts can use to keep an eye on more than 700,000 assets around the world.

Added value through SKF mechatronics

Less means often more, especially when it comes to “energy consumption”. To reduce this as much as possible SKF engineers have been looking for “anti-friction bearings” and for example developed a permanent magnet motor with active magnet bearings. With regards to safety and durability SKF sensor bearings with EMC filters are a real asset to the user.

More than the sum of all its parts

SKF converts the combined knowledge of experts from all five competence areas into solutions that fulfill their tasks perfectly and reduce total operating costs. This is “SKF knowledge engineering” in practice.

Mechanical drive technology from Siemens:
The Siemens Division Process Industries and Drives (PD) is world-leading in the field of products and services for the process industry. It offers integrated technologies along the entire drive train. Mechanical Drives therein is the specialist for mechanical power transmission. Grouped under the product names FLENDER and Winergy is a wide range of industrial gear units, turbo gear units, wind turbine gear units and couplings as well as diverse accessory and add-on parts. Customer services available worldwide complete the portfolio.



Siemens AG, Bocholt – Mechanical Drives



Partner of industry – worldwide

The drive components are used in many areas of raw material production and industry worldwide.

Hundred and twenty years of experience and hundreds of thousands of application cases are behind the product brands FLENDER and Winergy for wind turbine gear units. Today these high-quality components are manufactured to the same quality worldwide in factories in Germany, France, the USA, India and China.

All-purpose, high power-density, adaptable – FLENDER helical gear units

Helical, bevel-helical and planetary gear units were developed for operation in nearly all areas of mechanical drive technology. Highest possible efficiencies, rapid availability worldwide and an outstanding price-performance ratio have made the most comprehensive portfolio of series gear units to become best-sellers in the field of mechanical drive technology.

The basic portfolio offers a wide range of design variants over a torque range of from approx. 2 000 up to 5 500 000 Nm.

The basic portfolio makes short delivery times possible. Important add-on parts are already included in the basic range.

Reliable solutions for special applications

Each industry has its own requirements and needs specific solutions and expert guidance. Siemens has experience gained from decades of partnership with customers to rely on. The result is well-based, reliable solutions ideally adapted to all applications.

Couplings – always the right connection

Siemens offers a comprehensive portfolio of flexible, highly flexible, torsionally rigid and hydrodynamic couplings for a torque range of from 10 to 10 000 000 Nm for all drive requirements.

SMC Germany is a leading manufacturer of pneumatic and electric automation technology and your partner for customised solutions. In its 35-year history, the company has earned an excellent reputation in a broad range of industries such as automotive, food, energy, electronics – including photovoltaics – packaging and life science. The continuous focus throughout this time has been on: the customer and their specific task-related requirements. The objective is to secure a competitive advantage for customers from medium and large-scale businesses by developing complex and intelligent system solutions.



Set future standards with highly efficient customer-specific automation solutions



SMC Pneumatik is a part of the SMC Corporation, which has 16,000 employees worldwide and business sites in 82 countries. At the headquarters near Frankfurt am Main, in Egelsbach, Germany, there are currently more than 570 employees.

Within the range of individually-developed system solutions, SMC has outstanding references in a broad range of industries. The company places its focus on the customers' overall concept, and not on the individual components. SMC specialists always concentrate on an optimal automation solution in terms of flexible production, machine safety, and resource and energy efficiency. This is how SMC provides its customers with decisive competitive advantages.

The SMC product range includes the following product groups:

- Actuators (electrical and pneumatic)
- Valves and Manifolds
- Air Equipment
- Cooling and Temperature-control Units
- Ioniser
- Process Pumps
- Instrumentation
- Fittings and Tubings

Quality, energy efficiency and environmental conservation are subjected to the strictest possible standards. The company has ISO 9001 and ISO 14001 certifications since 1998.

In order to simulate various possibilities during the planning phase for the new construction, modification or expansion of a production system, SMC customers are given access to the new Industrial Application Centre (IAC) in Egelsbach. Together with SMC experts, the best possible automation concept for their precise task is determined. SMC also provides medium-sized business and industry-related employees with furthering educational programs.

With their consistent customer-orientation and the customers' involvement early on in the product development phase, SMC is setting crucial milestones for a successful future – for the company and its customers.





SMS Group has been engaged in the steel and nonferrous metal industries for more than 140 years. The companies within the group design and manufacture a complete range of plants and equipment for metallurgical and rolling plants, continuous casting, tube and copper technology industries. The manufacturing works in Hilchenbach is fully equipped with heavy duty machines for the production of the largest spur and helical spur gear units, SIEFLEX® gear-type couplings and SIEFLEX® gear-type self-aligning spindles.

Examples for a wide range of applications

We specialise primarily in drives for the steel and nonferrous metal industries and equip all makes of plants.

The individual components are designed and built to transmit the highest torques, among others, in horizontal and vertical rolling mill stands for flat and long products, slab sizing presses, coilers for hot and cold strip as well as shears and straightening machines.

Products drive technology

- Spur and helical spur gear units
- Pinion gear units
- Bevel and spur gear units
- SIEFLEX® gear-type self-aligning spindles
- SIEFLEX® gear-type couplings
- Converter tilting gear units
- Special gear units up to 300 t total weight, torques up to 5,000 kNm, drive capacities up to 20 MW, modules up to 40, up to 6,000 mm diameter, hardened and tempered, case hardened, single and double helical gearing
- Slipper-type spindles
- Drop-in gear sets





SMS Siemag AG
Hilchenbach
Wiesenstr. 30
57271 Hilchenbach
Germany



- Spare parts for all products
- On-site service
- Condition Monitoring

Products fluid systems

- Hydraulic and pneumatic plants
- Engineering of hydraulic installations
- Lubrication plants
- Rolling oil, roll coolant, and filtration systems
- Machine piping and media modules

MORGOIL® Bearings

MORGOIL® roll neck bearings enable hot and cold rolling mills for steel and non-ferrous metals to meet the highest demands with regard to dimensional accuracy, flatness and surface quality of the products rolled.

Supplies and services MORGOIL® bearings

- Complete oil film bearings up to 70 MN radial force and 1,800 mm bearing race diameter
- Modernisation of oil film bearings: neck sleeves, hydrostatic bearing bushings, sealing systems, hydraulic bearing fastening systems
- Spare parts for MORGOIL® bearings, MESTA® bearings and other oil film bearings in OEM quality
- Repairs of neck sleeves and bearing bushings, chocks and hydraulic cylinders.
- Basic data for chocks and roll necks
- Basic data for oil lubrication systems and pipelines
- After sales services



FINE CYCLO UA series



ZP – Planet Line



CYCLO DRIVE 6000 geared motor

Drive solutions from standard to customized

Innovative Drive Technology with a Tradition

For more than 80 years, the unique CYCLO drive principle has been the epitome of efficient drive solutions, reliability, long life cycles, high load capacity, and precision. These benefits are leveraged in areas of use such as medical technology, packing technology, materials handling, mining, print technology, machine tools, factory automation, and many others.

Sumitomo (SHI) Cyclo Drive Germany GmbH, a subsidiary of Sumitomo Heavy Industries (SHI), located in Markt Indersdorf, serves the EMEA market directly and via subsidiaries and distributors. The production facility at Markt Indersdorf was built specifically for the production of high-precision gears for use in the automation industries.

Sumitomo Cyclo Drive Germany offers their customers a comprehensive range of electrical and mechanical drive technologies.

- Robust and low-maintenance gears for all drive technology requirements
- Zero backlash gears for industrial automation, medical technology, and machine tools

- Special centrifuge drives for process technology, environmental technology and food and beverage industry
- Gears with extremely long live cycles for conveyor equipment
- Gears with high shock load capacity for the steel and iron industry, mining, and cooling towers

Delivery programme

- CYCLO DRIVE 6000 gears and gear motors
- FINE CYCLO precision gears
- Centrifuge drives
- BBB and Neo Hyponic series Bevel gears and gear motors
- HBB and HSM series Shaft mounted gears and gear motors
- Servo planetary gears and gear motors
- Servo 100 and Servo 6000 low-backlash servo CYCLO gears and servo gearmotors
- Servo motors
- Industrial gears and gear motors of the brands Hansen Industrial Gearboxes and Paramax

Sumitomo Cyclo Drive Germany's range of solutions encompasses standard drives and customer-specific modifications, including consulting, development, and manufacture.



Trust in Movement. Mechanical Power Transmission and Fluid Power from Voith

Voith is a specialist for intelligent drive solutions. Customers from highly diverse industries such as oil and gas, power generation, mining, machine tools, ship technology, rail and commercial vehicles rely on advanced technologies from Voith Turbo.

With intelligent drive solutions, Voith contributes to the reliable mobility of millions of people, goods and machines day after day. Drive technology from Voith is used all over the world. Our components and systems transmit and control power everywhere, even under extreme conditions.

Voith is always the link between driver and driven machine, between input and output – with its hydrodynamic, electronic and mechanical solutions. Our components transmit powers reliably and wear-free. They ensure safe and stepless speed control and protect the drivetrain against harsh jolts and consequently damage. Voith technology reduces torsional vibrations in the drivetrain and allows wear-free eco-friendly braking.

In all of these cases, Voith demonstrates its own drive for innovation with more than 10 000 patents and every year, another 400 are added.

Product categories:

- Actuators and control systems
- Connection couplings
- Highly flexible couplings
- Hirth serrations
- Hydraulic systems and components
- Fluid couplings
- Torque-limiting couplings
- Turbo gear units
- Universal joint shafts
- Variable speed drives





VOSS Fluid production



VOSS Inhouse electro plating



24° tube coupling

Tube connecting systems with long-term corrosion protection

VOSS Fluid is a leading provider of hydraulic connecting technology and a longstanding partner to the international mechanical engineering industry. The company's tube couplings are used in wide range of applications. With sound competence in the development, manufacture and assembly of compression couplings, VOSS Fluid has achieved a future-proof level of quality, safe process design of the company's own electroplating technology and the specially developed VOSS coat. As a coupling expert with intelligent delivery systems, VOSS Fluid provides customers with an optimum supply chain.

Every chain is only as strong as its weakest link. From the engineer's standpoint this means: high-performance machines can only work at full power if all components are designed to work perfectly together. This tenet is adhered to by plant and equipment manufacturers around the world and which is why they rely on hydraulic connection technology from VOSS Fluid. VOSS technology guarantees a long service life and resistance to the high stresses of the numerous

applications in stationary and mobile hydraulics. VOSS Fluid is thus a reliable and innovative technology partner who improves the safety and efficiency of valuable manufactured goods.

The company is a pioneer, especially in the area of corrosion protection, with its VOSS coat development. Under real-life operating conditions, the surface treatment based on a zinc-nickel base layer is far superior to other chromium VI-free alternatives available on the market. Sustainability aspects play an important role in the VOSS Fluid electroplating plants that meet state-of-art energy and technical standards. In addition to its own strict standards for product quality, VOSS Fluid focuses on reliable production solutions and offers a wide range of pre-assembly devices and tools. The range of offerings is completed by extensive application competence featuring training on leak-proof connecting technology and bespoke assembly audits for customers. VOSS Fluid is a single source for a full service package, from project planning to logistics, thus creating the basis for a long-term cooperation.



VOSS

VOSS Fluid GmbH • Lüdenscheider Str. 52-54 • 51688 Wipperfürth • Germany
Phone +49 2267 63-0 • E-Mail fluid@voss.net
Internet www.voss.net



LEADERSHIP IN HYDRAULIC SOLUTIONS

WEBER-HYDRAULIK Group specialises in the development of reliable customised hydraulic solutions. With over 2,200 employees working at 13 sites, we develop and produce cylinders, control blocks, valves, electronic units, power units and complex hydraulic systems for original equipment manufacturers and industries around the world. Our 75 years of experience and a favourable competitive position allow us to offer innovative, forward-looking systems such as suspension and steering systems and solutions for energy recovery. We consider ourselves a partner to our customers, offering reliable and efficient customised solutions.

Personalised advice, a solid relationship of trust with both suppliers and customers and optimised processes make us the ideal partner.

WEBER-HYDRAULIK offers a product range that includes hydraulic systems and components for commercial and industrial vehicles, agricultural and construction machinery, mobile cranes and forklift trucks. In addition to systems for original equipment manufacturers, we also develop and produce hydraulic system solutions for the renewable energy industry and oil and gas extraction.

As a global player with sites in Europe, North America, South America and Asia, we benefit from global networking, and having uniform operations and processes enables us to provide a consistent level of WEBER-HYDRAULIK service and high standards of quality to our customers around the world. For the future, we are building on established structures and traditional values, as well as innovative ideas and new developments. An international outlook mixed with the world-renowned status of a German company ensure that the WEBER Group is perfectly equipped for the future. WEBER-HYDRAULIK – Leadership in hydraulic solutions!





Hydraulics meets Electronics

The company W.E.St. Elektronik GmbH, located in the German region of Niederrhein is specialised in development of electronic components and closed-loop control techniques for hydraulic applications. ISO-certified quality, short delivery time, flexibility and unbureaucratic assistance result in high customer satisfaction.

Experience in the area of open-loop and closed-loop controlled applications are reflected in one of the most extensive product families for hydraulic applications. In addition to power amplifiers for proportional valves, positioning control, synchronisation control up to eight

15 years of business success means, worldwide delivery, highest quality and being “Brand Label” supplier for many OEM customers and hydraulic manufacturers.

axes, pressure control and pump control, W.E.St. is strongly active in the development of intelligent systems to simplify the start-up

procedure. Assistant tools are designed to support applications like position control and pressure control. The start-up procedure can be largely automated.

For the functional enhancement of the devices, fieldbus modules for CAN, Profibus, and different real time Ethernet versions are available. Simplest and efficient use being the main priority here.

Besides the standard devices in its product offering, W.E.St. partners with different hydraulic companies in new custom-fitted products for the hydraulic market. Adaptations of different standard modules, complete new development, for example on-board electronics for mobile and industrial applications, is part of the W.E.St. portfolio. The entire product development process, right from planning up to manufacturing and quality control, can be handled by W.E.St.

By cooperating with local partners, W.E.St. ensures high quality standards and product availability.

W.E.ST.

W.E.St. Elektronik GmbH • Gewerbering 31 • 41372 Niederkrüchten • Germany
Phone +49 2163 577355-0 • E-Mail info@w-e-st.de
Internet www.w-e-st.de



Innovation driver for mechatronic drive technology

The WITTENSTEIN AG develops customer-tailored products, systems and solutions for highly dynamic motion, extremely precise positioning and intelligent networking in the field of mechatronic drive technology.

High-precision planetary gearheads, complete electromechanical drive systems and AC servo systems and motors, to name a few, are designed, produced and marketed by around 1900 employees in every corner of the globe. The products sold by WITTENSTEIN's seven Business Units are typically used in robotic systems, machine tools, the packaging industry, materials handling and process engineering,

Formula One racing, paper and printing presses, medical technology and stage and lifting technology. Parallel to this, niche markets such as the aerospace industry, drive technology in human applications and offshore extraction of natural gas and oil under the ice sheet of the Norwegian Sea or nanotechnology have been systematically targeted. Acknowledged technological expertise and a tradition of innovativeness are the mainstays of WITTENSTEIN's success. With its fundamental orientation towards intelligent, mechatronic drive systems and a blend of micro and macro technologies, the company continues to develop its core know-how and competencies. WITTENSTEIN is inspiring for motion control and is a partner for efficient electromobility with its electrical gear systems. The company is a setter and promoter of trends in the development, production and marketing of components, 85 percent of all WITTENSTEIN products sold are less than five years old.



WITTENSTEIN AG • Walter-Wittenstein-Str. 1 • 97999 Igersheim • Germany
Phone +49 7931 493-0 • E-Mail info@wittenstein.de
Internet www.wittenstein.de

Shaping the future responsibly





ZF is a global leader in driveline and chassis technology with 122 production companies in 26 countries. In 2013, the Group achieved a sales figure of about €16.8 billion with approximately 72,600 employees. In order to continue to be successful with innovative products, ZF annually invests about 5 % of its sales (2013: € 836 million) in research and development. ZF is one of the ten largest automotive suppliers worldwide.

ZF Friedrichshafen AG in Passau is one of the largest employers in Lower Bavaria. More than 4,000 employees are working at the Passau location from where the Industrial Technology Division, one of four divisions within the ZF Group, is coordinated. 500 more employees are working at the plant in Thyrnau. As the management location of the Industrial Technology Division, Passau is responsible for about 9,000 employees at twenty locations throughout the world.

The plant I in Passau-Grubweg was founded in 1946. In the Central Division Steel of plant I, ZF manufactures finished parts such as gears and shafts from forged blanks. Plant II in Passau-Patriching went into operation in 1983. Here, the Central Division Casting machines raw castings and housings, and the Central Division Assembly assembles about 200,000 trans-

missions and axles per year. Patriching also accommodates the headquarters and administration of the Passau location.

Furthermore, the nearby ZF plant Thyrnau produces parts for axle drive units which are assembled at different Car Powertrain Technology locations worldwide. This plant was founded in 2001.

The ZF group is split into four divisions: Powertrain Technology, Chassis Technology, Commercial Vehicle Technology and Industrial Technology. Industrial Technology is the division where ZF bundles its activities for "Off-Road" applications. It comprises the development and production of transmissions and axles for agricultural and construction machinery as well as driveline technology for material handling systems, rail and special vehicles. The division is also responsible for the worldwide business of marine propulsion systems, aviation technology as well as the development and production of gearboxes for wind turbines. Test systems for all kinds of applications in driveline and chassis technology and the open telematics platform Openmatics are also included in the division's portfolio.

Beyond everyday's business, ZF Passau is also active in the social and cultural field. So, it is a matter of course for ZF to accept responsibility for society-related tasks. In addition to environmental protection, this responsibility also includes the support of numerous national and international relief projects. ZF's traditional value-awareness and sense of responsibility is at the center of these activities.

ZF is committed to a diverse education program and social relief programs and promotes the arts and culture.



ZF stands for system expertise, efficient products and provides overall solutions. By fostering the development of electronic solutions, applications for E-mobility and intelligent solutions ZF makes a significant contribution to efficiency.

Source: ZF Friedrichshafen AG



Imprint imprint

Published by

VDMA
Power Transmission Engineering
and Fluid Power Associations
Lyoner Str. 18
60528 Frankfurt am Main
Germany
Phone +49 69 6603-1332
Fax +49 69 6603-2332
E-Mail ant@vdma.org
fluid@vdma.org
Internet vdma.org

Publisher

VDMA Verlag GmbH
Lyoner Str. 18
60528 Frankfurt am Main
Germany
Phone +49 69 6603-1595
Fax +49 69 6603-1611
E-Mail verlag@vdma.org
Internet vdma-verlag.com

Layout and Design

VDMA Verlag GmbH,
Frankfurt am Main

Production

VDMA Verlag GmbH,
Frankfurt am Main

Printing

h. reuffurth gmbh,
Mühlheim am Main

Copyright 2015

VDMA Verlag GmbH

Editorial Team

Ms. Ann-Catrin Rehermann
Fluid Power Association
Ms. Solveig Thiede
Power Transmission Engineering and
Fluid Power Associations

Picture Credits

Cover: Schaeffler
Page 5: Siemens
Page 7: iStockphoto/alengo
Page 8: VDMA/Deutsche Messe
Page 9: VDMA/FVA
Page 10: Deutsche Messe, DLG, Messe München
Page 11: Fotolia
Page 12: pixelio.de
Page 13: pixelio.de/VDMA
Page 14: VDMA
Page 15: Schaeffler



Find more useful and interesting facts on your tablet or PC!

Videos, Links and Downloads:

Just follow the link to get special information on

www.vdma-verlag.com/mda15e

GO GLOBAL!

CHICAGO / SAO PAULO / MILANO / ISTANBUL /
NEW DELHI / SHANGHAI / HANNOVER



MDA Technologies represents

- electrical and mechanical power transmission
- control technologies
- latest innovations in hydraulics and pneumatics

www.mda-technologies.com

New business is just **one click** away.

VEREINIGTE FACHVERLAGE



VDMA

Power Transmission Engineering and Fluid Power

Lyoner Str. 18

60528 Frankfurt am Main

Germany

Phone +49 69 6603-1332

Fax +49 69 6603-2332

E-Mail ant@vdma.org

fluid@vdma.org

Internet www.vdma.org

ant.vdma.org
fluid.vdma.org